

VG 350 - 600

Installation and operating instructions



Table of Contents

1.	Precautions	2
2.	Description	3
2.1.	Fully modulating gas condensing unit	3
2.2.	Conformity and registration	4
3.	Scope of supply	4
4.	Technical data	6
4.1.	Main data / operating conditions	6
4.2.	Water quality	6
4.3.	Dimensions	8
4.4.	Technical specifications	10
4.5.	Correction values for different operating conditions	11
5.	Description of the boiler control panel	12
5.1.	Burner management:	12
5.2.	Governor types	12
6.	Installation guide	13
6.1.	General comments relating to installation	13
6.2.	Storage	13
6.3.	Combustion air supply	13
6.4.	Placement into the boiler room	14
6.5.	Planning dimensions	14
6.6.	Installing the unit	15
6.7.	Hydraulic connection	16
6.8.	Gas connection	17
6.9.	Electrical installation	17
6.10.	Flue gas installation	20
7.	Operating conditions	21
7.1.	Fuel	21
7.2.	Combustion air	21
7.3.	Filling the installation and water quality	21
7.4.	Requirements for operation	21
8.	Commissioning the condensing unit	22
9.	Operation	23
9.1.	Explanation of the control unit	23
9.2.	Operating level (status display)	23
9.3.	Parameter level	24
9.4.	Information level	25
9.5.	Explanations of the operating hours and pulse counter display	26
9.6.	Display of interruptions in the condensing unit	26
9.7.	Start process of the condensing unit	26
9.8.	Test program/chimney sweep operation	27
9.9.	Help in the event of errors	28
9.10.	Closing down the condensing unit after the heating season (summer operation)	29
9.11.	Commissioning the boiler when starting heating	29
10.	Maintenance	30
11.	Spare parts	30
	Annex 1: Error codes	31

1. Precautions

STEPS TO BE TAKEN IN CASE OF DANGER

- Close fuel supply, disconnect unit from mains using emergency stop or main switch (outside of the boiler room).
- Use suitable fire extinguishers to extinguish flames.
- **Occurrence of gas smell**
 - Ventilate the affected rooms thoroughly by opening doors and windows.
 - Do not use any electronic devices (mobile phone, etc.).
 - Do not activate any electrical contacts (light, motor, lift, door bell, etc.).
 - Do not ignite matches or lighters, and do not smoke.
 - Call the gas board or heating engineer.

PACKAGING

- After removing all packaging materials, check the contents to make sure that no damage has occurred during shipping. When in doubt, do not use the apparatus and contact the supplier.
- The packaging materials are to be disposed of properly.

THE BOILER UNIT

- Smooth boiler performance and manufacturer's guarantee are dependent upon adherence to the boiler installation, operation and maintenance instructions contained in this booklet.
- Never permit children or unauthorized persons to tamper with the equipment.
- The unit must be used only for its expressed application. All other uses are considered dangerous.
- The burner's minimum and maximum delivery settings, all pressures and temperatures must all be contained in the range stipulated in this manual.
- Modification of the equipment in order to alter its performance or application is prohibited.
- Do not open or tamper with components of the unit other than those parts of the unit that are subject to maintenance operations.
- Never touch the hot parts of the unit; these parts (flue gas conduit, sight glass, burner parts, etc) may remain hot for quite some time after the burner has switched off.
- Never touch the unit with wet parts of the body or without wearing shoes.
- When the unit is not to be used for a longer period, the main power switch on the electrical control panel must be switched off and the manual valve on the unit fuel supply line must be closed.
- The device contains components made of synthetic silicon mineral fibres (glass fibres, insulation wool). These components must be disposed of appropriately at the end of their life cycle. Local regulations must be observed.

INSTALLATION AND SETTINGS

- The installation and calibration of the unit must be performed exclusively by qualified personnel in conformity with existing regulations and the indications provided in this Manual.

THE BOILER ROOM

- The boiler room must be lockable and its external air openings must conform to the norms prevailing locally. When in doubt regarding air circulation, register the blower speed with the burner operating at its maximum delivery and the room ventilated only by the burner ventilation air openings and a second time with the door open. The blower speed registered in both cases must not differ. Should there be more than one unit in the same room, this test must be performed with all the equipment operating simultaneously.
- Never obstruct the boiler room's air openings, the burner fan suction opening, and any air ducts and ventilation.
- The equipment must always be protected against rain, snow, and freezing conditions.
- The boiler room must be kept clean and free of volatile substances that may be sucked into the fan and clog the inner burner or combustion head.
- The combustion air must be free of halogens (chlorine and fluorine compounds). The presence of halogen in the combustion air leads to great corrosion damage. If there is any doubt, the perfect quality of the combustion air must be ensured with an external air intake.

ELECTRICAL INSTALLATION

- Electrical connections must be made exclusively by qualified personnel and all prevailing electrical regulations must be scrupulously observed.
- Make sure that the electrical power supply used for connection conforms to the specifications indicated on the rating plate and in this manual.
- The unit must be correctly connected to an efficient ground system in conformity to the prevailing norms and checked and controlled for efficiency by qualified personnel when in doubt.
- Never confuse neutral wires with phase wires.
- The unit must be hooked up to the electrical network with a plug-socket connection that is such as to prevent inversion of phase and neutral. Install a master switch for the heating plant as requested by existing legislation.
- The entire electrical system, and all cable sections in particular, must be adequate to deliver the maximum absorbed power value indicated in this manual.
- If the mains power cable is found to be defective, it must be replaced only by qualified personnel.
- Never stretch power supply cables and keep them well away from sources of heat.

FUEL

- The unit must be fed with the type of fuel for which it has been preset as indicated on the rating plate.
- The fuel pressure must be according to the values listed in this manual.
- The fuel line that feeds the unit must be sized according to the requirements of local regulations. The line must be perfectly sealed. The fuel supply line must also be equipped with all the control and safety mechanisms required by local regulations in force. The line must be free from all impurities; take particular care that foreign matter does not enter the line during installation.
- The gas line must be checked for leakage during commissioning and after each disconnection.

MALFUNCTION

- If the unit stops working and goes into lock-out and does not resume operation after two or three manual lock-out reset attempts, do not attempt to repair, and contact a qualified specialist.
- All repairs required must be performed exclusively at a technical servicing centre authorized by the manufacturer using original spare parts only. Failure to observe the above may compromise the reliability and safety of the equipment.
- Any failure or damage resulting from improper use or intentional damage will relieve the manufacturer from any guarantee obligation.

MAINTENANCE

- Maintenance must be performed by qualified personnel regularly or at least once a year.
- Prior to performing any maintenance operations, switch off the power supply by using the main switch and cut off the fuel supply as well.
- Only parts indicated by the manufacturer in the Spare Parts Catalogue may be replaced.
- In order to avoid all types of health hazards, suitable clothing and a protective mask must be worn for work on or with components made of synthetic silicon mineral fibres (glass fibres, insulation wool).

2. Description

2.1. Fully modulating gas condensing unit

The VARINO GRANDE condensing unit sets new standards for energy-saving heat generation from natural gas. The unique power modulation range up to 1:12 enables an almost continuous operation during the main period of the heating season. Based on the drastically reduced number of starting and stopping processes and the low average use of power this results in considerable benefits in relation to environmental loading and efficiency. In addition, reactions to changes in heat consumption are faster since the condensing unit is already working, as a rule, due to the long running times of the burner.

The unique power modulation range up to 1:12 is achieved by a complete pre-mix burner with moving burner surface, which is extended in proportion to the heat consumption. With an increase in power the active burner surface with the flame openings is enlarged. At the same time the volume of gas and air is increased so that the individual flames do not change but merely increase in number. The special, patented design of the flame openings enables minimum emissions of carbon monoxide and nitric oxide.

The burner control based on a micro-processor with fan speed correction ensures a uniform combustion quality. Local conditions relating to the unit such as geographic height, flue, ingoing air lines, etc. are automatically recorded during commissioning and corrected by the computer. In addition, daily deviating effects such as air pressure changes, temperature changes, changes in the composition of natural gas, etc. are taken into consideration by permanently checking the oxygen concentration in the waste gas by means of an oxygen sensor and the control of the required speed of the fan. This results in an additional saving in electric energy.

Control takes place via optional modules to all accessible interfaces found on the market (e.g. digital control, 0-10V or bus) in addition to in-built external temperature control (option).

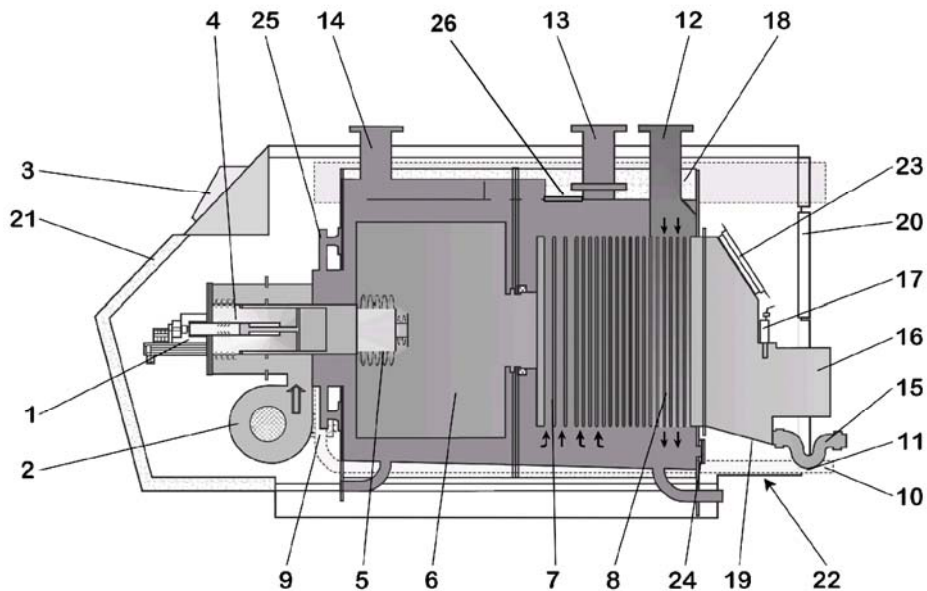

- | | | | |
|-----|--------------------------------------|-----|---|
| 1. | Fully modulating burner | 14. | Supply from unit |
| 2. | Combustion air fan | 15. | Siphoned condensate flow |
| 3. | Micro-processor control | 16. | Waste gas pipe |
| 4. | Mixing chamber | 17. | O ₂ sensor |
| 5. | Burner surface | 18. | Insulation |
| 6. | Combustion chamber (stainless steel) | 19. | Condensate trough (stainless steel) |
| 7. | Stainless steel heat exchanger | 20. | Casing |
| 8. | Stainless steel condenser | 21. | Casing hood |
| 9. | Gas control compact unit | 22. | Combustion air inlet |
| 10. | Isolating cock | 23. | Cleaning cover, flue gas side |
| 11. | Gas inlet | 24. | Cleaning cover, water side |
| 12. | Low temperature return | 25. | Cleaning plug, water side (VG-TB) |
| 13. | High temperature return | 26. | Inspection cover heat exchanger (VG-TB) |

The boiler body consists of parts in contact with flue gas made out of high quality stainless steel. The concept of maintaining the return temperature can therefore be dispensed with. The high and low temperature returns enable simultaneous supply of return water with high and low temperature without impairing the efficiency of the heat

exchanger by forming a mixing temperature. The heat exchanger and condenser are constructed in a natural circulation design so that operation is possible with a random combination of high and low temperature return water volumes. The condensate which arises during operation is collected in a stainless steel trough under the condenser and then siphoned off.

The VARINO GRANDE is available in two design versions. The standard design is a monoblock version. In the case of narrow delivery conditions, the boiler block of the unit can also be supplied in several parts as an option. In this version (VG-TB), it can be still be brought through doors that are only 800 mm wide.

Since the components of the VARINO GRANDE condensing unit have already been co-ordinated and optimised, connection to a hydraulic network and commissioning are very simple.

2.2. Conformity and registration

This device fulfils the requirements of the gas appliances directive 2009/142/CE, the low-voltage directive 73/23/EEC, the EMC directive 89/336/EEC and the efficiency directive 92/42/EEC. The boiler range is ECA approved.

- CE-ID-No. 0063AT3524

The gas appliance category is indicated on the nameplate.

NOx class EN656: 5

3. Scope of supply

The VARINO GRANDE condensing unit is a compact heat unit that is ready for connection. It consists of the following components:

- Boiler body with flue gas heat exchanger (monoblock or optionally separated)
- Modulating gas burner with fan(s) (2 for VARINO GRANDE 350-450)
- Boiler control panel with burner management, control of the internal safety devices and connection possibilities for external signals, depending on the selected variant
- Front hood
- Compact gas fittings
- Heat insulation with sheet-metal casing
- Air filter(s)
- Condensate connection with siphon
- Counterflanges on the forward flow and return flow pipes
- Scraper to remove sludge from the water chamber below heat exchanger
- Optionally: a gas pressure regulator 300 to 20 mbar with filter

Please check whether all parts are included in the scope of supply.

The products are delivered on wooden pallets:

Standard monoblock version (VG – MB)

- 1 pallet for boiler block with waste-gas collector, boiler cover and insulation
- 1 pallet for burner hood and packing unit with boiler casing
- 1 pallet for burner, fan(s), air filter(s), gas block, boiler control panel, documentation and various

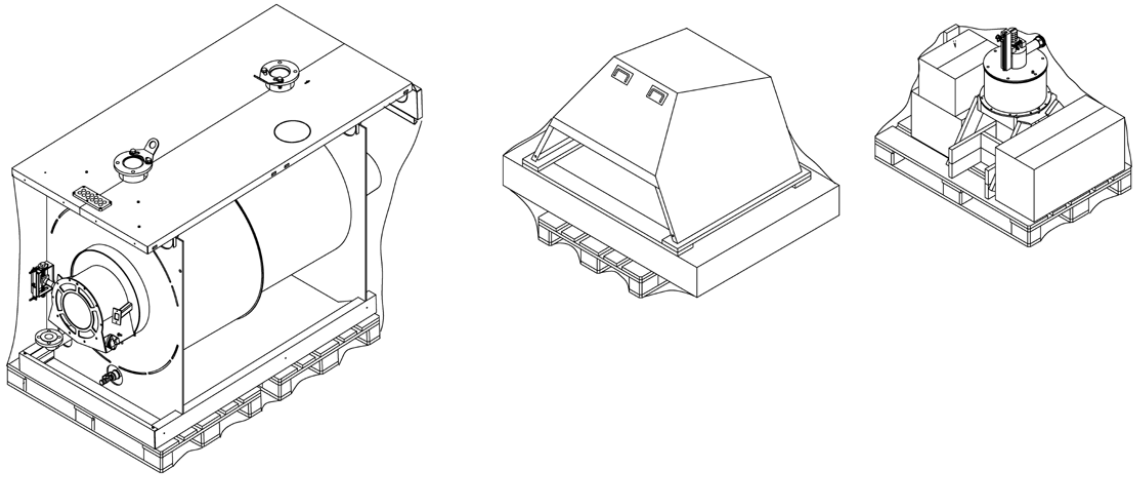

Separated version of the boiler block (VG – TB)

- 1 pallet for heat exchanger
- 1 pallet for combustion chamber
- 1 pallet for burner hood, waste-gas collector and packing unit with boiler casing
- 1 pallet for burner, burner support, fan(s), air filter(s), gas block, boiler control panel, documentation and various small parts
- 1 pallet for boiler cover, boiler base and insulation

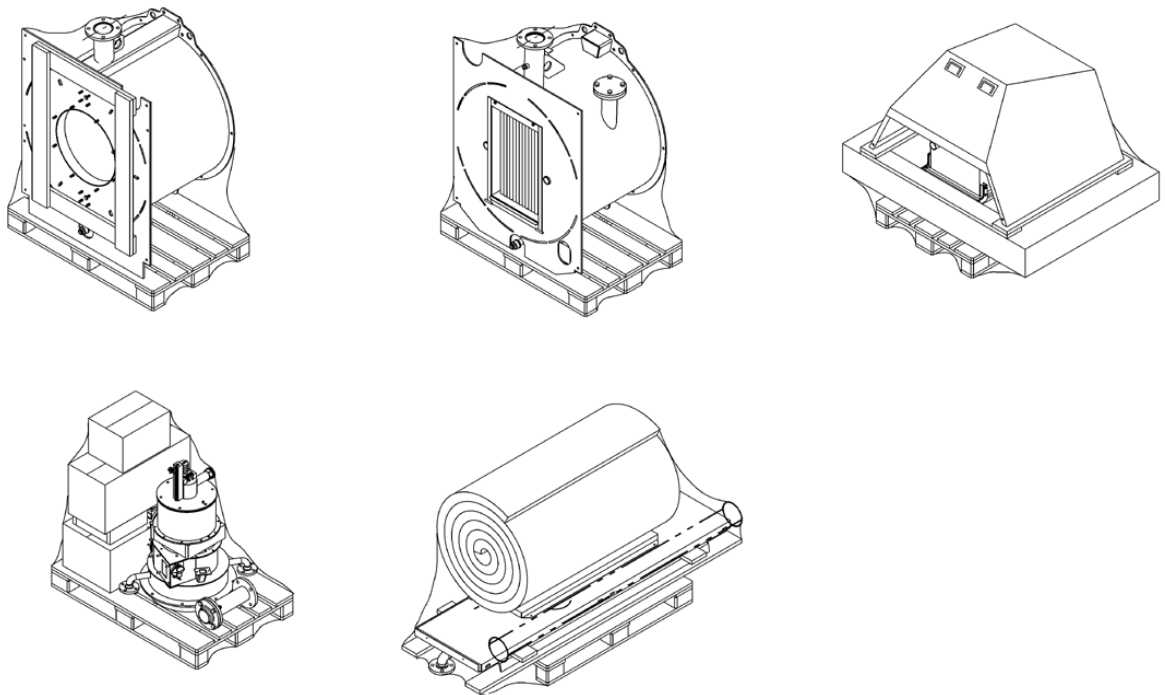

4. Technical data

4.1. Main data / operating conditions

Operating pressure		6,0 bar
Test pressure		9,0 bar
Boiler supply and return pipe flanges		PN 6
Max. operating temperature		100°C
Min. return temperature		no limits
Max. CO ₂ -content	with natural gas	11.7%
(dry flue gas)	with propane	13.7%

4.2. Water quality

The following rules apply once the boiler is put into service and remain valid until the end of life of the product.

Preparing the water system before putting the boiler into service

For any installation (new or renovation), the water system pipes must be thoroughly cleaned. The purpose of this initial cleaning is to eliminate germs and residue that can cause deposits to form.

In **new installations** in particular, residue from grease, oxidised metal, and even copper microdeposits must be removed.

In **renovated installations**, cleaning should focus on removing sludge and the products of corrosion formed when the unit was last in operation.

There are two types of methods for cleaning and removing sludge: a high intensity approach that takes a few hours and a slower, more gradual approach that takes several weeks. This first type of cleaning must be done **before connecting the new boiler**, and with the second type, a filter should be installed on the back of the boiler to capture loosened deposits.

The cleaning performed prior to installation improves performance, reduces energy consumption, and resists scaling and corrosion on the unit. A professional (water treatment) should carry out the cleaning.

Protecting the unit against scaling

Water naturally contains dissolved calcium ions and carbonates that cause scaling (calcium carbonate) to form. To prevent excessive deposits, take precautions with regard to the **water used to fill the unit: TH < 10°f**

Water must be added during the life of the boiler. The new water adds scaling to the water system. **The amount of fill water plus the amount of make-up water added during the life of the unit should not be more than three times the water capacity of the heating system.** Also, the hardness of the make-up water must be controlled. **Make-up water: TH < 1 °f**

Adding a large amount of untreated water always contributes a significant amount of scaling. To monitor this and to detect problems, **a system water meter must be installed.**

Failure to comply with these guidelines (such that the fill water plus the make-up water is more than three times the water capacity of the heating system) requires a full cleaning (to remove sludge and scaling) to be performed.

Additional precautions are required for operation:

- ✓ When the unit has a water softener, the equipment must be inspected on a regular basis in order to ensure that it is not outputting chloride-rich water into the system. The concentration of chlorides must always remain below 50 mg/l.
- ✓ To prevent the build-up of calcium deposits (such as on exchange surfaces), the unit should be brought into service slowly, starting by operating at a low power with high primary water flow.
- ✓ When the tap water lacks the desired qualities, **water treatment is required.** The fill water must be treated, and whenever new water is added, the make-up water must also be treated.
- ✓ Installations with multiple boilers require all of the boilers to be brought up simultaneously at minimal power. Doing this prevents the calcium in the water from depositing on the exchange surfaces of the first boiler.
- ✓ When working on the unit, avoid draining it completely; only the required parts of the system are to be drained.

The rules listed above are designed to minimise scaling on the exchange surfaces and thus to increase the life of the boilers.

To optimise how the equipment operates, plan to remove its calcium deposits. This must be done by a specialized company. Also, before putting the unit into service, verify that the heating system is not damaged (ex. leaks). If it has excessive scaling, the unit's settings for operation and for water treatment must be adjusted.

Protecting steel and stainless steel boilers against corrosion

Corrosion can affect the iron components used in boilers and heating systems, which is directly related to the presence of oxygen in the water heater's water. Dissolved oxygen that enters the unit when it is being filled for the first time reacts with the equipment materials and quickly disappears. Without refreshing the oxygen through significant contributions of water, the unit might not experience any damage whatsoever.

However, it is important to follow the sizing rules and installation guidelines in order to prevent oxygen from continuously flowing into the heating water. From these rules, we have:

- ✓ Preferably an expansion vessel with a membrane rather than an open expansion vessel that allows direct passage
- ✓ Internal pressure with the unit of more than 1 bar cold
- ✓ Remove leaky (permeable) components that are letting out more gas than as if they were sealed.

If the guidelines above are followed, the unit's system water has the proper characteristics to last a long time: **8.2 < pH < 9.5 with a water concentration of < 0.1 mg/l.**

If there is a chance that oxygen could enter the unit, you must take additional precautions. Adding an oxygen scavenger (ex. sodium sulphite) is highly recommended. We recommend directing any water treatment questions to specialists, which can provide:

- The appropriate treatment based on the characteristics of the unit
- A monitoring agreement with a guarantee as to the results

For units in which **the water comes into contact with heterogeneous materials**, such as copper or aluminium, **appropriate treatment is recommended** in order to ensure that the unit will last. In most cases, this consists of adding corrosion inhibitors (in the form of chemical solutions) to the unit. Referring to a water treatment specialist is recommended.

The use of glycol-based water is prohibited.

Unit monitoring

If the recommendations listed above (new installation or renovation) have been followed, the unit monitoring is limited to:

- Checking the amount of make-up water (fill water volume + make-up water volume < 3 times the unit volume)
- Checking the pH level (stable or slightly increasing)
- Checking the total hardness (stable or slightly decreasing)

We recommend monitoring these parameters two to three times a year. Note: Monitoring the quantity of make-up water is critical to the long life of the unit.

If any of these parameters deviates from the above recommendations, refer to a water treatment specialist to correct the problem.

Setting up a plate exchanger

If the recommendations listed above cannot be met, you can set up a plate exchanger to separate the primary system from the secondary system, which protects the boiler from undesirable effects.

Setting up a filtration system

A filtration system on the back of the boiler is recommended in order to remove suspended particles from the unit.

4.3. Dimensions

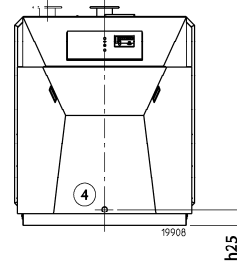
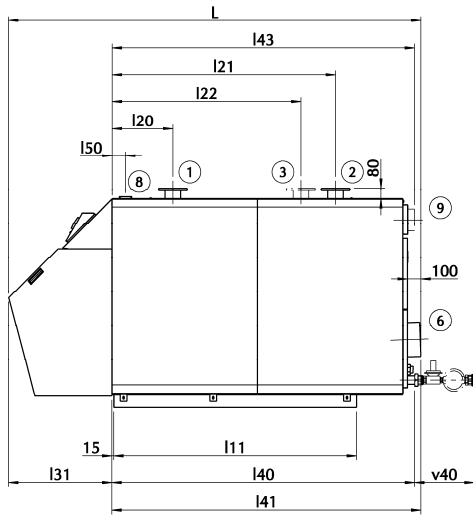

Connections:

1. Supply from boiler
2. Return to boiler
3. HT return (optional)
4. Discharge
- 4'. Second discharge (TB)
5. Condensate connection
6. Waste gas connection
7. Gas connection
8. Entrance opening for external electrical cables
9. External air intake (optional)
10. Cleaning cover, water side

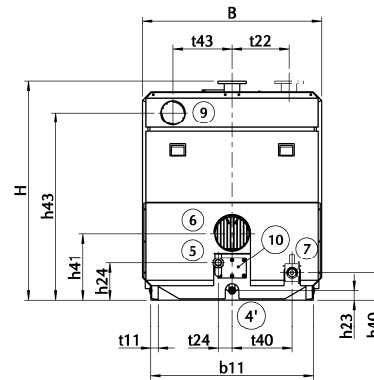

VG 350 - 600

VARINO GRANDE - standard (VG - MB)			350	400	450	500	550	600
Overall dimensions	L	mm	2866			3028		
	B	mm	1170			1320		
	H	mm	1465			1615		
Largest single part	l x b x h	mm	2225 x 1050 x 1465			2323 x 1200 x 1615		
Weights								
Heaviest single part	G 15	kg	720			890		
Empty weight	G 11	kg	975			1180		
Water quantity	G 16	L	435			590		
Boiler								
Erection site	l 11	mm	1710			1783		
	b 11	mm	1050			1200		
	t 11	mm	55					
Hydraulic system								
Supply from boiler	l 20	mm	417			446		
	t 20	mm	0					
	D 20	mm	DN 100					
Low temperature return	l 21	mm	1552			1641		
	t 21	mm	0					
	D 21	mm	DN 100					
High temperature return (optional)	l 22	mm	1287			1386		
	t 22	mm	360			439		
	D 22	mm	DN 80					
Discharge	h 25	mm	120			120		
	D 25	R	1 1/4 "			1 1/4 "		
Neutralisation (condensate connection)	h 24	mm	274			275		
	t 24	mm	102					
	D 24	mm	DN 48					
Burner / hood								
Hood	l 31	mm	686			758		
	G 31	kg	9.4			11.6		
Gas / waste gas / inlet air								
Gas	l 40	mm	2170			2255		
	t 40	mm	385			442		
	h 40	mm	120			200		
	D 40	R	2 "			2 "		
Lenght of 300 mbar kit (option)	v 40	mm	423			423		
Waste gas	l 41	mm	2180			2270		
	h 41	mm	464			493		
	Ø (outside/inside)	D 41	mm	253 / 250				
Recommended flue diameter 1	D 42	mm	250			300		
External air intake (optional)	l 43	mm	2220			2220		
	t 43	mm	370			435		
	h 43	mm	1238			1371		
	D 43	mm	DN 160					
Electrical system								
Entrance opening for electrical cables	l 50	mm	95					

1: Basis: 40 m stainless steel smooth; 2 x 90 ° bends; 3 m waste gas tube

We recommend precise calculation with a chimney calculation program based on DIN 4705

VARINO GRANDE - separated version (VG - TB)			350	400	450	500	550	600
Differences from VARINO GRANDE - Standard								
Largest single part	l x b x h	mm	747 x 1050 x 1470			792 x 1200 x 1621		
Weights								
Heaviest single part	G 15	kg	439			581		
Empty weight	G 11	kg	1145			1435		
Water quantity	G 16	L	540			765		
Hydraulic system								
Additional discharge backside	h 23	mm	70					
	D 23	R	1 1/4 "					

4.4. Technical specifications

Model VG			350	400	450	500	550	600		
Power										
Boiler nominal calorific power qF	max.		kW		350	400	450	500	550	600
	min.		kW		35	35	35	50	50	50
Modulation rate			1 :		10	11	13	10	11	12
Full load power qN	80/60 °C		kW		341	390	439	489	536	584
	40/30 °C		kW		375	425	470	530	580	630
Efficiencies										
Efficiency DIN 4702-8	75/60 °C		%		106.6	106.3	106.1	106.6	106.5	106.3
	40/30 °C		%		109.5	109.4	109.3	109.5	109.5	109.4
Pressures and mass flows										
Gas connection pressure	min.		mbar		12			12		
	min. @ qN	4	mbar		18	18.7	19.3	18.3	18.6	19
	max.	3	mbar		50 / 300			50 / 300		
pp-max external air intake	max.		Pa		150	100	50	150	100	50
Free delivery pressure of flue	max.		Pa		100	100	60	100	100	90
Amount of condensates at 40/30 °C	max.	1	kg/h		38	39	40	57	59	60
Gas flow, NG type E	min.	2	nm ³ /h		3.5			5.0		
	max.	2	nm ³ /h		35.1	40.1	45.2	50.2	55.2	60.2
Exhaust gas mass flow, NG type E	min. wet		g/s		15.0			21.1		
	max. dry		g/s		131.7	150.6	169.4	188.1	206.9	225.8
	max. wet		g/s		148.6	170.0	191.1	212.5	233.6	255.0
Gas flow, NG type LL	min.	2	nm ³ /h		4.1			5.8		
	max.	2	nm ³ /h		40.8	46.7	52.5	58.3	64.2	70
Exhaust gas mass flow, NG type LL	min. wet		g/s		15.0			21.7		
	max. dry		g/s		134.2	153.3	172.5	191.7	210.8	230.0
	max. wet		g/s		151.1	172.8	194.2	215.8	237.5	258.9
Gas flow, LG type P	min.	2	nm ³ /h		1.4			1.9		
	max.	2	nm ³ /h		13.6	15.5	17.4	19.4	21.3	23.3
Exhaust gas mass flow, LG type P	min. wet		g/s		14.7			21.1		
	max. dry		g/s		133.6	152.5	171.7	190.8	209.7	228.9
	max. wet		g/s		146.9	168.1	189.2	210.0	231.1	252.2
Exhaust gas data, losses										
O2-content	dry		%		3.25					
CO2-content	dry	1	%		9.86					
NOx (EN656, DIN4702-8)		1	mg/kWh		< 45	< 50	< 50	< 55	< 55	< 55
CO (DIN4702-8)			mg/kWh		< 5					
Exhaust gas temperature at 80/60 °C	qFmin	1	°C		60.1			60.1		
	qFmax	1	°C		70	73	76	70	72	74
Exhaust gas temperature at 40/30 °C	qFmin	1	°C		30.1			30.1		
	qFmax	1	°C		40	43	46	40	42	44
Stand-by loss qB	70 °C		W		390			510		
Stand-by loss qB	35 °C		W		115			150		
Electrical data										
Electrical power consumption	qFmin		W		102	102	102	123	123	123
	qFmax		W		480	540	600	693	757	820
Connection to mains (single phase, 16 A)			V/Hz		230 ±10% / 50 ±1% (EN50160)					
Hydraulic data										
Boiler water operating pressure (cold)	min.		bar		0.5					
	max.		bar		6					
Water resistance	ot=10K		mbar		60	79	100	112	135	160
	ot=20K		mbar		15	20	25	28	34	40
Water flow	min.		m ³ /h		-					
	max.		m ³ /h		40			54		
Operating temperatures	max.		°C		100					
	STB		°C		110					
Noise pressure levels										
In chimney		5	dB(A)		94	95	95	95	95	95
1 m in front of burner hood			dB(A)		51	52	53	52	53	54
With background noise of			dB(A)		35					

Values acc. EN656 at:

- O2=3.25% dry lamda=1.17

- T-air=20°C, rel. humidity=60%, p-baro=100kPa

1: Operation with NG, type E

2: nm³ at 0°C, 1013 mbar

3: Pressures until 100 mbar conditionally possible, 300 mbar version optional

4: With pressureless exhaust. Add 0.1 mbar per 10 Pa back-pressure.

5: 2 m from the boiler, with one 90° elbow

05.11.2007

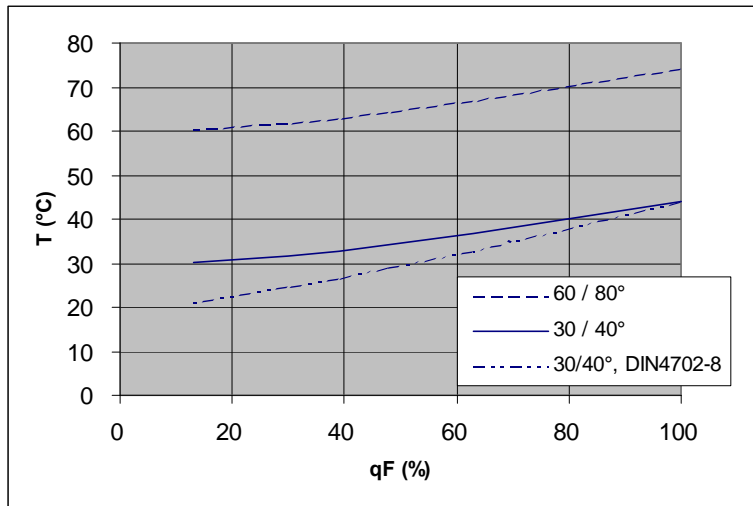

Flue gas temperature-diagram of a VARINO GRANDE as function of the load

4.5. Correction values for different operating conditions

4.5.1. Stand-by loss correction values

Average temperature difference *	Δt_m	°C	30	40	50	60	70
Stand-by loss correction	Δq_B	%	-40	-20	± 0	20	40

* Average temperature difference = Average boiler water temperature minus ambient air temperature
 Average boiler water temperature = Average of supply and return temperature

4.5.2. Nominal load related to altitude

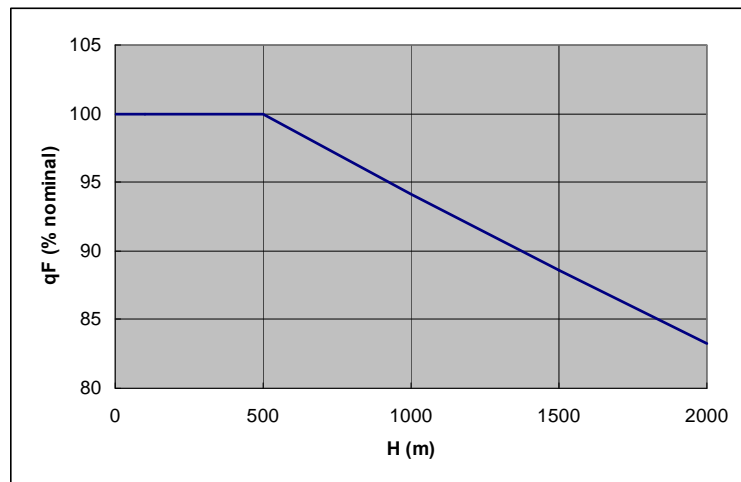

The actual correction may be smaller than this, since a margin has been allowed for barometer fluctuations.

This also takes into account using the optional intake duct for external air intake (max. pressure loss according to chap. 4.4).

5. Description of the boiler control panel

The control panel of the VARINO GRANDE condensing unit consists of the two systems burner management and installation control.

5.1. Burner management:

The functions of a traditional heating unit are integrated in the expanded functions of the burner manager. The burner manager is a micro-processor controlled electronics device which records and controls all data on the boiler/burner. All safety-relevant measurements are recorded and monitored. The burner manager is linked with an oxygen sensor which measures the oxygen partial pressure (O₂ content) in the waste gas. If a deviation from the desired value is measured, the electronics corrects the quantity of inlet air to the combustion process via the speed-controlled combustion air fan.

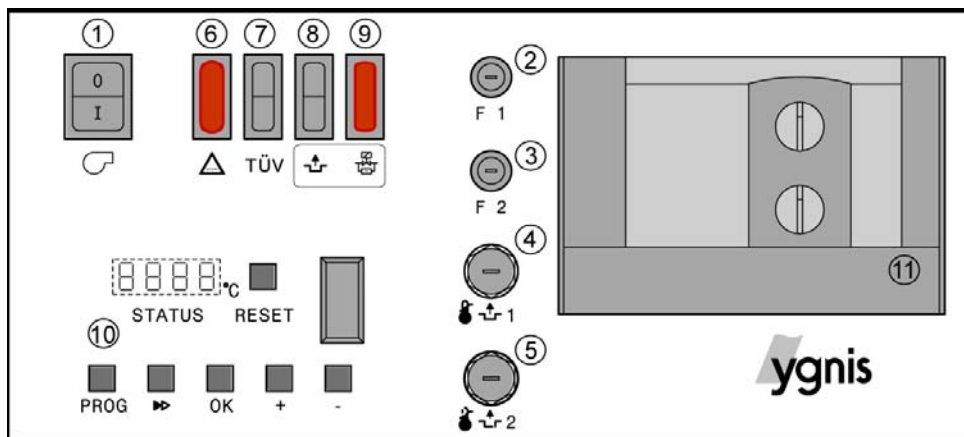

Key: Control panel for condensing unit

- 1 Burner switch ON/OFF
- 2 Fuse F1, 10 A burner / boiler
- 3 Fuse F2, 6.3 A heating controller (optional)
- 4 STB safety temperature limit device
- 5 STB 2 waste gas STB safety temperature limit device (optional)
- 6 Fault lamp, external faults
- 7 TÜV button
- 8 Release key of the sealing control (optional)
- 9 Fault lamp, sealing control (optional)
- 10 Operator station with display
- 11 DIN standard cut-out for accommodating an Ygnis heating controller (optional)

5.2. Governor types

A wide range of system controls has been designated for the VARINO GRANDE condensing unit.

Based on the modular design, the planner is in a position to install the condensing unit specifically for the installation with the appropriate type of control.

The modern micro-processor controlled Ygnis heating controller enables an optimum heating circuit and hot water control.

RDO 243 governor

Heating governor providing regulation for 1 mixing circuit and automatic water loading device.

RDO 383 governor

Heating and master cascade governor for 2 mixing circuits, 1 automatic water loading device and DHW circulation pump, can be added for use with 6 other mixing circuits by means of additional modules RZM 510, with three other automatic water loading devices by means of additional modules RZM 515 and the cascade control with three other boilers by means of additional modules RZM 530.

6. Installation guide

6.1. General comments relating to installation

6.1.1. Basic details

The perfect operation of the condensing unit and the manufacturer's warranty are only guaranteed if installation and operation take place in accordance with the instructions from the manufacturer and the condensing unit and burner are maintained on a regular basis.

Installation and commissioning of the electric, firing and heating unit parts should only be carried out by authorised specialists in accordance with local regulations.

Defects and damage which are caused by improper handling or damage caused by force, release the manufacturer from this warranty.

6.1.2. Regulations

The installation of the condensing unit and heating plant is to be exclusively carried out by specialists in accordance with the applicable standards and constructional specifications.

6.2. Storage

If the condensing unit has to be stored before being placed in the boiler room then it should be stored in a dry and frost-free area.

6.3. Combustion air supply

The supply of combustion air directly from outside must be ensured through openings which cannot be shut-off.

Minimum air consumption 1.6 m³/h per kW boiler power.

Minimum free cross-section for the opening of the combustion air = 6 cm² per kW boiler power.

Important: The combustion air should not contain large amounts of dust and particles.

Furthermore, it must be free of halogens (chlorine and fluorine compounds). An excessive presence of halogen in the combustion air leads to great corrosion damage. The maximum permitted amount of halogen in the combustion air is 5 ppm.

Halogen compounds are found in spray cans, thinners, cleaning agents, degreasing agents and solvents, among others. In addition, halogen emissions are strongly suspected in the vicinity of dry cleaners', hair dressing salons, swimming pools, printing offices and washing machines installed in the same room.

In the case of doubt, the perfect quality of the combustion air must be ensured with an external air intake. Make sure that there is a minimum loss of pressure, since this could impair the performance of the burner (see chapter 4.4). A built-in air duct for the external air intake is available as option.

6.4. Placement into the boiler room

The condensing unit can be placed in position in various ways.

The condensing unit is delivered on wooden pallets which are suitable for a fork lift truck, pallet roller or armoured rollers.

In addition, the condensing unit is delivered with lifting eyes and the boiler can be placed by means of lifting gear.

The components may only be assembled by trained personnel.

6.4.1. Positioning by means of wooden pallets

After positioning the condensing unit, the wooden pallets must be removed.

6.4.2. Positioning by means of lifting gear

The condensing unit is delivered with lifting eyelets and the boiler can be placed by means of a lifting gear. After positioning, the eyelets must be removed.

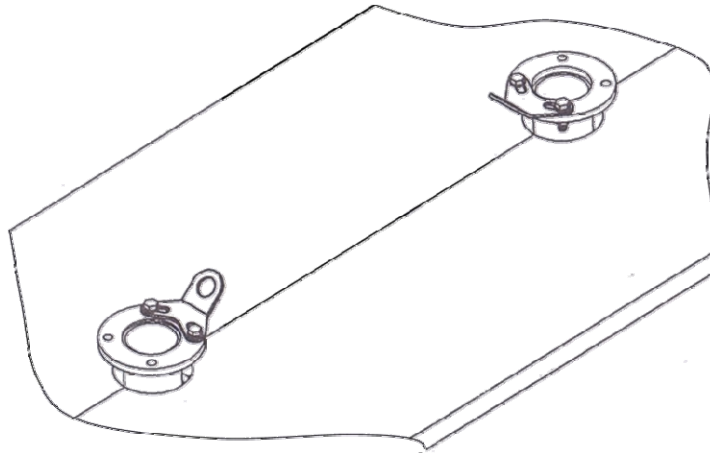

6.5. Planning dimensions

6.5.1. Minimum distances for positioning the unit

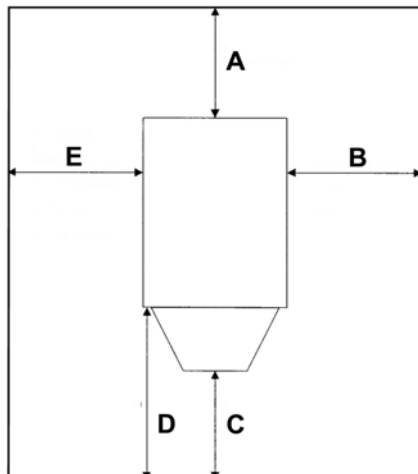

- | | | |
|----|--|------------------------|
| A: | Recommended | 800 mm |
| | Minimum | 600 mm |
| B: | 500 mm needed to assemble the casing | |
| C: | Minimum | 1200 mm (from casing) |
| D: | Minimum | 2000 mm (from support) |
| E: | 500 mm needed to assemble the casing. | |
| | This part of the casing needs to be dismantled for disassembly of the gas train. | |

6.5.2. Boiler base

If the floor of the boiler room is moist or loose, a sufficiently high boiler base must be provided. Moisture does not go well with electrical equipment!

Otherwise, no base is needed for the unit.

6.5.3. Boiler support

It is possible to mount the boiler on vibration dampers (available as option) to reduce noise transmission caused by vibrations.

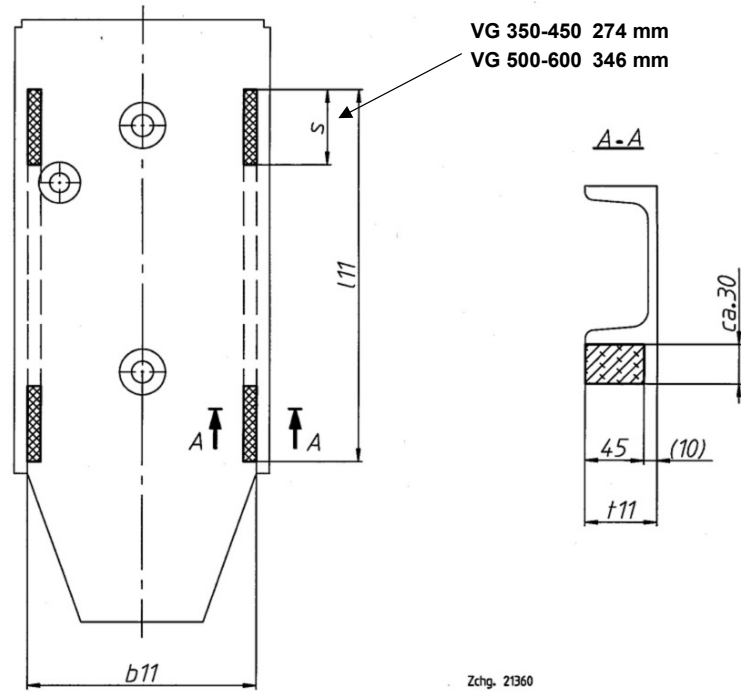

Dimensions and positioning of the vibration dampers
(further dimensions see chapter 4.3)

When the condensing unit has been placed correctly, the vibration dampers are put underneath it. To do this, the unit is lifted by approx. 5 cm on one side using a hoisting device. Next, half of the vibration damper elements are placed underneath, and the elements must lie flush with the base frame at the front. In addition, make sure that the elements are flush with the inner side of the base frame. The unit can now be carefully lowered onto the elements. The remaining vibration dampers are now placed underneath the opposite side of the unit in the same way.

Afterwards, you can start installing the connection tubes on the water and flue gas side.

Attention! Once the unit is filled up, it will come down by further 2-3 mm.

6.6. Installing the unit

The unit is only allowed to be installed by authorised specialist personnel. Such personnel are familiar with the unit and know the special aspects relating to its installation.

Each module (burner, gas line, fan, casing, boiler control panel, etc.) is supplied with its own installation instructions. We recommend that you keep them together with these instructions. Some of these instruction documents are also required for startup, subsequent operation and maintenance (gas compact unit, control panel, governor, ignition electrode, O₂ sensor).

The boiler casing may only be assembled after the boiler has been completely connected and the heating installation has been finished. Otherwise, there is a risk of damage.

6.7. Hydraulic connection

6.7.1. General notice

For the hydraulic connection of the heating system and water heaters– in particular with regards to technical safety devices such as safety valves, expansion tanks, etc. – refer to generally accepted engineering rules as well as locally applicable standards, specifications and regulations.

If boilers are installed in **garret-based heating plants** or at the highest point of the heating system, then boilers will have to be provided with additional safety devices (such as protections against water shortage). Observe the minimum operating pressure as specified in chapter 4.4. Act in compliance with local safety regulations in force at all times.

Boiler's maximum operating pressure and the maximum operating temperature are given in chapter 4.1.

No minimum level of the amount of circulating water is required.

6.7.2. Water quality

Observe the required water quality according chapter 4.2. Anti-freeze should not be used.

Before connecting the boiler to an **old installation**, it is necessary to flush the whole heating system.

It is recommended to provide for a sludge separator.

Damage can occur from **corrosion** when oxygen continuously enters the heating water through open installations, expansion tanks that are too small, floor heaters with pipe material that is not oxygen-tight, etc.

If this cannot be prevented, additional measures are necessary in the form of correctly used oxygen binding agents or chemicals. If it is not possible to realize an installation without oxygen entrance, a **system separation** must be set up using heat exchangers.

6.7.3. Boiler return flow

The condensing unit is fitted with a high temperature return flow in addition to the normal low temperature return flow. Heating elements are connected to these with the maximum temperature level.

In order to ensure a high degree of efficiency of the boiler in each operating condition, care should be taken to ensure that the low temperature return flow is supplied in each case.

It is not necessary to maintain the return flow temperature at a given level.

6.7.4. Draining the condensate

The condensates that result during condensation contain combustion products that are more or less acidic. Any necessary approval for draining the condensate into the sewer system must be obtained from local authorities.

A condensate neutralisation set is available as an option, if desired

If the condensate is drained directly into the sewer system, then this must take place via an open funnel/hopper.

Important:

The recuperator is delivered with a siphon arranged in the casing. **It must be ensured that no additional siphon is installed since this would prevent the condensate from draining away. For the same reason, the line to the funnel/hopper must have a slight gradient and should not show any slack!**

6.8. Gas connection

This condensing boiler was set in the factory to operate using the gas specified on the gas setting label.

Please obtain an adaptation kit as per the following table, for use with any other type of gas:

		350 – 450 kW	500 – 600 kW
AT / CH ES / GB IT	G20	406063	406064
	G31	406401	406402
BE / FR	G20 / G25	406063	406064
	G31	406401	406402
DE	G20	406063	406064
	G25	406339	
	G31	406401	406402
LU	G20	406063	406064
NL	G25	406339	
	G31	406401	406402

ATTENTION: Any operation involving a change of gas type must be done by a qualified professional.

The maximum gas connection pressure (flow pressure) must not exceed the value given in the chapter "Technical data". The VARINO GRANDE is optionally also available as 100-300 mbar version. This version comprises a gas pressure regulator with filter that is to be mounted directly on the boiler's gas train. Mounting and regulating instructions come with the equipment.

Before the condensing unit is connected to the gas line, it must be made sure that the line has been blown through and is free from particles and chips.

A shut-off valve must be installed in the gas supply line to the burner.

If boiler rooms without pressure relief openings are located in the basement, a shut-off device automatically controlled by the burner may have to be fitted in the gas line (observe local regulations). In this process, the gas supply is interrupted during operational stand-still of the burner. A supply terminal is available on the boiler for this purpose (external gas valve).

Notes: The whole gas installation may only be carried out by a licensed installation company. Installation must be in accordance with local regulations.

At commissioning as well as after each opening the gas train is to be checked for leakage (leak spray).

The installation may only be operated with the intended gas quality – observe additional plate on burner!

100-300 mbar version: Before the condensing unit is connected to the gas line, the supplied gas pressure regulator with filter must be fitted directly on the gas train of the unit!

6.9. Electrical installation

6.9.1. Precautions

The electrical installation must be carried out by an authorised electrician from beginning to end. In carrying out the electrical installation, local regulations as well as any standards and specifications in force must be complied with.

Modifications to the internal wiring in the unit are not allowed without our written permission. Modifications performed by the customer that lead to a defect in the unit or to material damage to installation components or buildings as a result of non-observance of this instruction release the manufacturer from his warranty observation.

Observe the installation instructions supplied with the control panel!

Important: Electrical connections, especially the connection to the mains, should only be made after all other assembly and installation work has been completed.

Locally made installations (raceways, etc.) must not be clamped to the boiler's panel work!

6.9.2. General information

Mains connection	Single-phased alternating current 230 VAC $\pm 10\%$, 50 Hz $\pm 1\%$ acc. EN50160. Fuse maximum 16 amps (slow)
Current consumption	(See "Technical data"). In the case of installed heating controllers, it must be taken into account that the individual connections of the pumps must not exceed the maximum current consumption. Precise data on the individual connections (pumps, mixer drives etc.) can be found in the corresponding electrical diagram.
Internal wiring	The burner and all monitoring elements are readily wired by the factory.
Wiring by customer	All parts to be connected to the unit on site such as sensors, pumps, mixer drives and external safety devices are to be connected to the terminal strips on the boiler control panel. Inspection work and the correct functioning of the third-party devices are the responsibility of the electrician.
Temperature sensor	All temperature sensors to be assembled by the customer (depending on boiler control panel variant) are delivered in a cardboard box with an installation instruction.

6.9.3. Sensor assembly

Junction boxes or sockets are to be avoided. Sensor and extra-low-voltage cables must be laid separately from mains lines. Use own sensor cable with max. 100 m length, cable 2 x 1 mm² not screened

Cable length:	up to	25 m	cable cross section:	0.25 mm ²
Cable length:	up to	50 m	cable cross section:	0.5 mm ²
Cable length:	up to	100 m	cable cross section:	1.0 mm ²

External sensor: In 2/3 facade height or on 1st floor not above windows or below roof preferably installed on the north or north west side. Avoid direct sunlight. Position to be arranged with heating planner.

Forward flow sensor: *Supply flow clip-on sensor*
assemble directly behind the pump (approx. 0.5 m) in the supply flow of the heating or, if the pump is assembled in the return flow, approx. 1.5 m after the mixer position. Assembly: assemble on the bare pipe with supplied clamp band, without conductive paste

Supply flow immersion sensor
assemble directly behind the pump (approx. 0.5 m) in the supply flow of the heating or, if the pump is assembled in the return flow, approx. 1.5 m after the mixer position. Assembly: assemble in the pipe bend against the flow direction of the heat transfer medium

Room remote controls Assemble in the main living quarters on the interior wall. Do not subject to the influence of sun or external heat (chimney wall, radiator proximity, drafts, televisions, lighting fixtures). Do not cover with furniture or curtains, mount approx. 1.2 – 1.5 m over the floor. Seal installation pipe against drafts. All room sensors and room remote controls are "active" and therefore directly connected to the device bus. The cable lengths of all lines on the device bus must not exceed the maximum length of 200 m! Cables 2x1 mm², wires not screened, lay separately from power lines, junction boxes and sockets are to be avoided.

Return flow sensor, boiler sensor, safety temperature limit devices and temperature monitor are positioned by works and supplied as-wired.

The O2-sensor is delivered separately and is mounted at commissioning in order to prevent eventual damage to the sensor during the construction period.

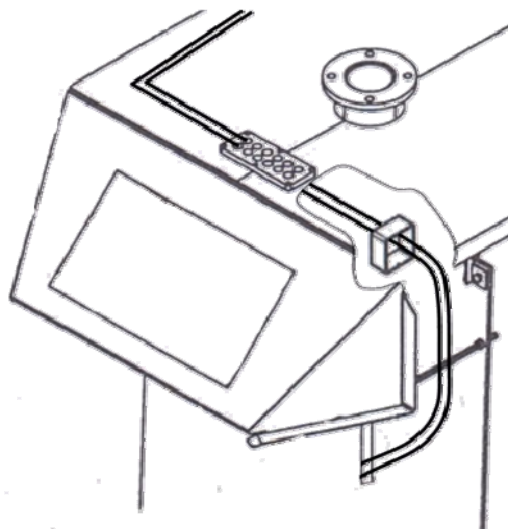

The electrical cables and lines must be laid and secured as shown in the illustration. For strain relief, the cables should be fastened with cable binders to the threaded rod of the boiler nose piece. Mains and extra-low-voltage cables (sensor lines, bus lines etc.) are to be routed separately. Unnecessarily long cable loops must not be rolled up inside of the boiler casing.

6.10. Flue gas installation

The pertinent rules of technology as well as the country-specific regulations and valid standards must be observed.

6.10.1. Requirements

Waste gas installations must be corrosion-resistant, leak-tight in terms of gas and condensate and withstand the static and operating requirements. The flue mouth must ensure unhindered emergence of the waste gases (a flue cap is not recommended).

The right choice of the diameters of the flue gas installation will depend on the height of the installation, the number of elbows to be applied and other factors. The necessary calculations for the dimensioning of the installation shall be carried out by the manufacturer of the installation who shall ensure that the boundary conditions related to the available delivery pressure will be in accordance with chapter 4.4 in those cases where the installation is planned to be operated with a positive back-pressure (appliance type B23P).

Attention: Appliance type B23P is only valid when the appliance is installed with flue systems meeting the norm EN1856-1 with CE-marking and classified as P (overpressure).

6.10.2. Execution

The condensing unit is to be placed as near as possible to the flue. The connection between the condensing unit and the flue must be designed with a gradient so that the condensate which is produced can flow from the waste gas tube into the condensate trough of the boiler. This connection should not contain many bends nor cross-sectional changes. The connection of the waste gas installation to the boiler must ensure tightness with regard to gas and condensate. A standard commercial coupling (e.g. Straub coupling) is best suited for this purpose. The waste gas installation does not have to be provided with its own condensate drain pipe. The condensate outlet on the VARINO GRANDE is dimensioned large enough so that condensate and rain water can be disposed of.

If the waste gas line is made out of material which is not temperature-resistant a safety temperature limiting device is to be fitted in the waste gas line. This can be delivered completely assembled as an option or supplied by the flue constructor (regulating thermostats are inadmissible). In the latter case, the potential-free contact must be connected to the terminals of the boiler control whereby a safe disconnection of the burner is ensured if the temperature is exceeded (external safety).

It is recommended to ground plastic waste gas lines, since these become statically charged during operation.

6.10.3. Measurement connections for firing control

Measurement connections in accordance with the official regulations must be provided for waste gas, temperature and pressure measurements in the waste gas tube (supply by flue constructor).

7. Operating conditions

7.1. Fuel

This condensing boiler was set in the factory to operate using the gas specified on the gas setting label.

IMPORTANT: Please refer to chapter 6.8 for use with any other type of gas.

Important: The use of other gases such as for instance biogas is not permitted.

7.2. Combustion air

The combustion air should not contain large amounts of **dust**.

The blower intake opening is provided with a label referring to this requirement. **This label must be removed before starting up the unit.** The person who removes the label guarantees that the combustion air is free from dust or that an air filter is fitted.

Furthermore, the combustion air must be free of **halogens** (chlorine and fluorine compounds). An excessive presence of halogen in the combustion air leads to great corrosion damage. Make sure that no paints, thinners, cleaning agents, degreasing agents, solvents, chlorine containers, etc. are stored in the boiler room!

7.3. Filling the installation and water quality

The installation must be thoroughly rinsed before it is finally filled.

When filling for the first time and refilling, check the quality of the water in accordance with the values recommended in chapter 4.2. Poor water quality leads to damage in heating installations from calcification and corrosion. On the other hand, the service life, functional reliability and efficiency can be increased using appropriately treated water.

During the filling process, the circulation pumps should be switched off and all ventilating valves opened, so that the air in the system can completely escape. The filling process is finished when the operating pressure has been reached.

7.4. Requirements for operation

The maximum operating pressure and the minimum and maximum temperatures to be observed are listed in chapter 4.1.

Never switch off the mains voltage except for maintenance work on the control panel. The oxygen sensor must always be heated, even during summer operation (otherwise there is a risk of condensation forming inside the sensor).

8. Commissioning the condensing unit

The condensing unit may only be commissioned by a specialist trained on the product.

In order to ensure successful commissioning of the unit, the following points must be guaranteed by the electrician.

- The unit is installed hydraulically, electrically, on the gas and waste gas side and is ready for commissioning. With regard to the correct function of the O₂ sensor, it is particularly important to ensure that:
 - the condensation drain line does not have a double siphon and the line does not sag,
 - the unit is electrically connected and integrated so that it will remain connected to the main even when no heat is required, thereby guaranteeing that the O₂ sensor will be heated.
- A complete equipotential bonding must be guaranteed.
- The boiler room must be clean, free from dust and be able to be locked.
- All material and equipment which does not belong to the boiler room, must be removed.
- A fresh air supply to the boiler room must be ensured when doors are closed.
- The hydraulic system must be purged.
- The connection pressure of the water must be within the range defined in the "Technical data".
- If subsequent supply is necessary, then the water should be slowly fed to the filling and draining pipes in order to avoid pressure surges.
- A leakage test of the gas line must have been carried out.
- The connection pressure of the gas line at the unit connection must be the value required by the table "Technical data".
- The connection of the waste gas line to the waste gas pipe must be leak-tight for the flue gas and condensate.
- The internal siphon of the unit in the condensate drain must be filled with water.
- If the condensing unit is supplied with a condensate neutralisation unit, then this must be prepared in accordance with separate installation and operating instructions.
- It must be possible to provide maximum heating capacity to the heating system for at least 30 minutes, since the self-calibration of the unit that is running at this time does not allow any interruption.

After ensuring the above-mentioned points, the unit is ready for commissioning by a specialist.

If the above mentioned conditions, guidelines or regulations have not been observed, the specialist can refuse to commission the VARINO GRANDE condensing unit. Temporary commissioning of the condensing unit (e.g. during construction phases) which leaves out certain conditions must be expressly approved by the manufacturer.

9. Operation

Read this section of the manual with great care and get an installer to explain the heat producing system in all its different aspects: regulation and control.

9.1. Explanation of the control unit

RESET - Key	Release key - fault
PROG - Key	Selector key - program
▶> - Key	Step key
OK - Key	Store key
+ - Key	Increase parameter value
- - Key	Reduce parameter value

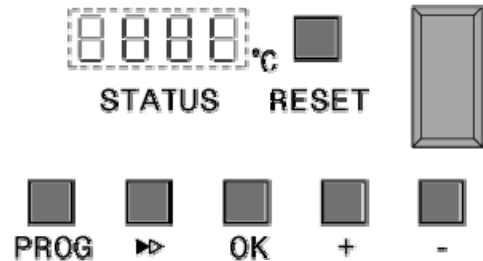

Status display

Pressing the "PROG" key changes the program level. Each time the PROG key is pressed, the program changes one level further.

- **Operating level** (status display). This program level shows the current status with the boiler temperature.
- **Parameter level**. In this program level, the different parameters can be called up.
- **Information level**. This program level gives information about the current statuses and sensor values.

If no key is pressed, the display automatically switches to the operating level (standard picture) after 20 min.

Service plug

Interface for service diagnostics system. The interface is protected against damage by a plastic cover. (only for expert personnel)

9.2. Operating level (status display)

The first figure shows the status, the last two figures the boiler temperature in °C.

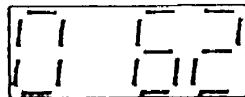

Display (figure 1)

Display	Current status of the condensing unit
0	Waiting status, no heat requirement
1	Pre-flushing, burner ventilates the combustion chamber
2	Ignition procedure of the burner
3	Burner in operation
4	Burner in operation, status "Intelligent Modulation Control"
5	Waiting status for - minimum gas pressure - air pressure - desired burner position

- 6** Desired temperature reached, normal switch off performed via switching hysteresis. (Active with "fixed value" control, "analog desired value" control or with integrated heating controller).
- 8** No or too small gas pressure present, start process was cancelled; condensing unit checks in 5 min. intervals whether gas pressure is present.
- 9** Boiler switched off due to exceeding of the electronic temperature monitoring.
- A** Condensing unit switched off via burner switch on control panel or an external safety device connected to the boiler control panel has interrupted the control circuit, or the temperature monitor has been set too low.
- C** The oxygen sensor is calibrated
- d** Burner is gauged (can only be reset by service personnel)
- E** (Without flashing) no signal from oxygen sensor
- H** Temperature of the oxygen sensor is being checked

9.3. Parameter level

Entry by pressing the **PROG** key once. The entry is confirmed by **lighting up** of the point after the **1st digit**. The **first digit** shows the step number and the last **two figures** the set value.



Step	Parameter	Setting range
1	Maximum boiler temperature TK in °C	20 to 100°C
2	Min. external temperature TA in °C	- 20 to 5°C
3	Min. boiler temperature TK in °C	10 to 60°C
4	Max. external temperature TA in °C	5 to 15°C

Parameters 2-4 are only active with "fixed value" control

Parameter values are set with the keys + or -. The modified value must be confirmed with the **OK key**. Switching to the next parameter takes place via the **▶> key**. When leaving the parameter level (by pressing the PROG key) the set values are accepted and overwritten in the EEPROM.

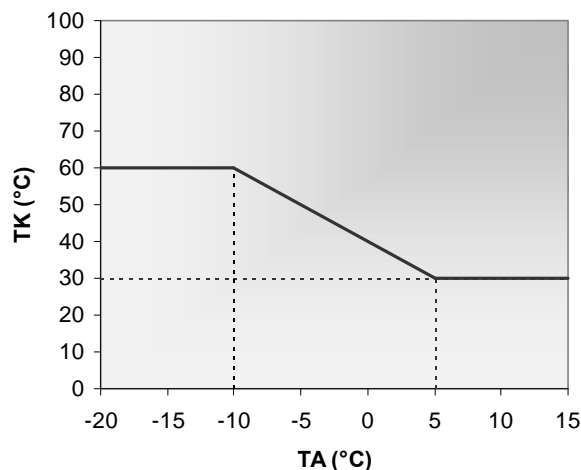

9.4. Information level

Entry by pressing the **PROG** key twice. The entry is confirmed by the point after the **1st figure flashing**. The first figure shows the step number, the last two figures the current value. By pressing the **▶>** key, the individual steps can be read one after the other.



Step no.	Information (actual values)	
1	Boiler temperature in °C	
2	Return flow temperature in °C	
3	Status display with 4 figures	
Figure 1 =	Heat requirement	0: no requirement 1: requirement
Figure 2 =	Burner switch/external safety	0: start not possible 1: start possible
Figure 3 =	Air pressure monitor	0: switch open 1: switch closed
Figure 4 =	Gas pressure monitor	0: switch open 1: switch closed
4	External temperature in °C (only with "fixed value" control; otherwise display -36)	
5	Waste gas temperature in °C	
6	Speed of the combustion air fan in RPM	
7	Desired boiler temperature (only with "fixed value" control, "analog desired value" control or fitted heating controller)	
8	Operating hours counter	
9	Burner setting in % (10 – 100%)	
10	Start pulse counter	
11	Oxygen level in waste gas in % O ₂	
12	Speed correction for fan (deviation from the stored pre-setting) in RPM. Corresponds to the correction to maintain the set oxygen level.	

9.5. Explanations of the operating hours and pulse counter display

Operating hours	9999 = 0-9,999 hours
	999.9 = 10,000-99,999 hours display in steps of 10
	99.99 = 100,000 - 279,000 hours display in steps of 100
Pulse counter	9999 = 0-9,999 pulses
	999.9 = 10,000-99,999 pulses display in steps of 10
	99.99 = 100,000 - 279,000 pulses display in steps of 100

The operating hours and start pulses are overwritten in the EPROM in a 24-hour cycle. After a power failure, the counter shows the value that was stored before the failure occurred. The maximum counter reading is 279,000 hours or approx. 32 years. After that, it returns to 0.

9.6. Display of interruptions in the condensing unit

When an error occurs this appears automatically on the display. All figures flash in the display. The first figure shows **E for ERROR**, the two following figures designate the error code.



For help in the event of errors see chapter 9.9, for the various error codes with their meaning see Annex 1: Error codes.

9.7. Start process of the condensing unit

9.7.1. Normal starting sequence

step	display	process
a	1	The mechanical ventilation is started (optional)
b		Check whether the differential pressure monitor of the room ventilation is closed (optional)
c		The external safety gas valve is opened
d		The burner moves to 50% load position
e	5	The gas pressure monitor is inspected
f		The air pressure monitor is inspected (must be open)
g		The combustion air fan is started and run to maximum speed
h		The air pressure monitor is inspected (must be closed)
i	1	The burner ventilates the combustion chamber for 30 seconds
k		The burner moves to start position
l		The combustion air fan is run to the starting speed
m	2	The preliminary heating time is started (approx. 10 seconds)
n		The gas valve (multiblock) is opened
o		The burner ignites
p		Switching over from ignition by incandescence to ionisation measurement
q	3	Release of the O ₂ correction
r		Release of the power modulation of the burner

If a defect or irregularity is noted during the starting procedure then the start is repeated or interrupted, a corresponding error code is shown in the display.

9.7.2. Starting sequence after power failure or after acknowledging error

In contrast to the normal starting sequence, for safety reasons after a power failure or after acknowledgement of an error, the combustion chamber is ventilated with fresh air for 5 minutes and the oxygen sensor is subsequently recalibrated. The previously described sequence changes as follows:

step	display	process
a	1	The mechanical ventilation is started (optional)
b		Check whether the differential pressure monitor of the room ventilation is closed (optional)
c		The external safety gas valve is opened
d		The burner moves to 50% load position
e	5	The gas pressure monitor is inspected
f		The air pressure monitor is inspected (must be open)
g		The combustion air fan is started and run to maximum speed
h		The air pressure monitor is inspected (must be closed)
i	1	The burner ventilates the combustion chamber for 300 seconds and the oxygen sensor is brought to its operating temperature
j	C	The oxygen sensor is calibrated to the ambient air. In the display, H is shown and then for approx. 5 seconds C.
k	1	The burner moves to start position
l		The combustion air fan is run to the starting speed
m	2	The preliminary heating time is started (approx. 10 seconds)
n		The gas valve (multiblock) is opened
o		The burner ignites
p		Switching over from ignition by incandescence to ionisation measurement
q	3	Release of the O ₂ correction
r		Release of the power modulation of the burner

9.8. Test program/chimney sweep operation

Press "+" and "-" keys at the same time and keep them pressed until the status indication changes to "tEst" on the display. The VARINO GRANDE condensing unit is now in the test program. The display alternately shows "tEst" and the current burner position in %. The burner can be brought to any position desired with the "+" and "-" keys. To exit the test program, it is necessary to press the "PROG" key.

Note: The test program can be activated for a maximum of 20 minutes; after that, the unit automatically changes back to normal operation.

Attention: The desired boiler temperature is not in operation during the test program. The boiler temperature can rise to the value set at the temperature monitor, which causes the boiler to shut down!

9.9. Help in the event of errors

ATTENTION: Opening the casing and manipulating the electrical connections is **EXTREMELY DANGEROUS!** The mains fuse must be switched off before the front cover is removed.

WARNING: Due to external connections on the boiler control panel, individual cables or components on the VARINO GRANDE condensing unit can still be live even when the mains fuse is switched off.

9.9.1. No error code in the display

Unit is cold, the VARINO GRANDE condensing unit is not in operation, no error code is shown in the display.

Status display: **First figure = 0**

Meaning: The condensing unit has no heat requirement and therefore no start command.

Possible cause: *Ygnis heating controller (if present):*
The heating controller is set to summer operation or switched off.
The operating instructions of the heating controller provide information on the individual functions and applications of the heating controller.

External control with heating controller:
- the external heating controller should be checked.
- The heating curve may be set too low

Further procedure: Check cause, unit will start automatically when required.

Status display: **First figure = 8**

Meaning: Gas pressure monitor input is open

Possible cause: - The gas pressure is inadequate
- The gas cock is closed
- External safety gas valve is defect.
- The external mechanical ventilation does not work or builds up too little pressure.

Further procedure: Check cause, unit will start automatically when required.

Status display: **First figure = A**

Meaning: The condensing unit is switched off

Possible cause: *Fault lamp "external faults" lights up:*
- The neutralisation set connected to the boiler control panel is overfull (if present),
- external safety devices connected to the boiler control panel (e.g. water shortage fuse, minimum/maximum pressure monitor, or external STB's) have been triggered.

Further procedure: The cause is not related to the condensing unit. After remedy of the external cause the unit will start again without actuating the RESET button. A 5 minute ventilation period will precede the start.

Possible cause: *Fault lamp "external faults" does not light up:*
- The burner switch on the control panel is switched OFF
- The maximum temperature set on the temperature monitor has been exceeded.

Further procedure: Check cause, unit will start automatically when required.

Possible cause: *Fault lamp "sealing control" is lit (only when a sealing control has been optionally added to the gas block):*
- The gas supply is closed
- A leak has been found at one of the two gas valves of the gas block.

Further procedure: After the cause has been checked, the fault message must be acknowledged with the "sealing control" release key. If the device still does not start after acknowledgement has been made several times, the customer service must be informed.

Status display:	Alternating display "noO2" ↔ standard display
Meaning:	Failure of the O ₂ control.
Possible cause:	<i>O₂ sensor defective</i> - The condensing unit continues to run in emergency mode for max. 72 hours . After this time has expired, the unit shuts down. - The safety block can only be released after the cause has been eliminated.
Further procedure:	Inform the customer service and indicate the error code as well.

9.9.2. Display flashes

Unit is cold, condensing unit is not operating, information on the display flashes.

Status display:	First figure = E Figure 3 + 4 = Error code
Meaning:	Determine error code by means of Annex 1: Error codes.
Further procedure:	Note error code Remedy cause and acknowledge with " RESET " key
Note:	The starting sequence up to the ignition of the flame lasts at least 5 minutes after the RESET key is pressed. If the VARINO GRANDE condensing unit should return to error after the acknowledgement, then please contact the customer service.

9.9.3. Error codes

See Annex 1: Error codes, page 31.

9.10. Closing down the condensing unit after the heating season (summer operation)

- Burner switch on control panel to OFF. The figure A appears with the current boiler temperature on the status display. Units that have an installed Ygnis heating controller automatically switch to summer operation.
- Close gas shut-off cock on the boiler rear wall or in the gas supply line.

Note: The mains voltage should **not** be switched off by means of an external main switch because the oxygen sensor must also be heated during the summer (power consumption approx. 1 watt).

If sanitary water production takes place in summer operation with the VARINO GRANDE, the burner switch may not be switched off.

In the case of frost danger when the unit is switched off, the installation must be emptied.

9.11. Commissioning the boiler when starting heating

- Open the gas shut-off valve on the boiler rear wall or in the gas supply line.
- Burner switch on control panel to ON. After a long stand-still it is possible that the burner will have a false start (error message E 2) upon the initial start test. Use the "**RESET**" key to reset the unit. If a false start occurs again, please notify your customer service.

10. Maintenance

maintenance or cleaning work can be carried out on the boiler or burner by the operator. The following points must be observed for optimum operation:

- The combustion chamber must be kept clean
- A fresh air supply must always be guaranteed
- The connection between the waste gas pipes of the condensing unit and the waste gas unit must be gas and condensate leak-tight.

Periodical checks and maintenance operations

- Check manometer with circulation pump off. Low water or pressure level indicates that the system must be filled up with water. Observe the required water quality according chapter 4.2.
- Check that the expansion chambers function properly
- Check safety valves as well as heating and hot water system blowers
- Check the internal siphon of the unit in the condensate drain. It must be filled with water.
- Clean the air filter(s) (and check the gas filter on the optional 300 mbar version)
- Boiler and chimney cleaning: The waste gas collector of the condensing unit is equipped with a cleaning cover for the activities of the chimney sweep. After this person has finished his work, make sure that the cover is carefully mounted, in order to prevent the uncontrolled escape of waste gases and condensate as well as intrusion of air (which results in an incorrect O₂ signal).
- The water chamber below the heat exchanger is equipped with a cleaning cover. After you have drained the boiler water, this cover allows you to check whether sludge has collected in the boiler. Use the scraper delivered with the unit to remove the sludge. Then carefully close the cover. Refill while observing the required water quality according chapter 4.2. After you have refilled the system, check for leaks.
The divided version of the boiler (VG-TB) is furthermore equipped with an inspection cover above the heat exchanger. The packing of this cover is to be checked for tightness during the annual boiler inspection.
- Annual general boiler and burner check by the customer service.

Notes: Cleaning work on the boiler is normally not required and may only be carried out after having dismantled the igniter and the O₂-sensor.

Dismantling and reinstallation of the burner are to be carried out in accordance with instructions from the manufacturer.

Maintenance work on the burner may only be carried out by specialists trained on the product.

The device contains components made of synthetic silicon mineral fibres (glass fibres, insulation wool). In order to avoid all types of health hazards, suitable clothing and a protective mask must be worn for work on or with these components.

11. Spare parts

Available at your customer service.

Annex 1: Error codes

Error code	Meaning
00	Ionisation error (igniter may be wet)
01	Short circuit 24 V circuit
02	No flame when igniting (repeated false starts)
03	Internal defect
04	Permanent locking after power failure with previous defect
05	Internal defect
06	Internal defect
07	Internal defect
08	Air pressure monitor does not close
11	Internal defect
12	STB (safety temperature limit device) has released
13	Internal defect
14	Internal defect
15	Internal defect
16	Internal defect
17	Internal defect
18	Boiler temperature too high
19	Return flow temperature too high
28	Combustion air fan of the boiler does not rotate
29	Combustion air fan does not cut off
31	Boiler sensor short-circuit
32	Return flow sensor short-circuit
36	Boiler sensor interruption
37	Return flow sensor interruption
41	Internal defect
42	Internal defect
44	Internal defect
45	Defect calibration of the oxygen sensor (poss. water on sensor)
47	O ₂ sensor feed level was defective during calibration
49	O ₂ sensor error (sensor signal asymmetrical, poss. EMC)
50	O ₂ sensor error (no measurement cycle)
51	O ₂ sensor error (measurement difference t1/t2, poss. EMC)
58	No calibration possible- (gas valve possibly not leak-tight)
61	Air pressure monitor does not open
65	Combustion air fan desired speed is not reached
70	Error potentiometer on the burner (operating range too large)
71	Short-circuit potentiometer on the burner
72	Interruption potentiometer on the burner
73	Constant value of the potentiometer on the burner (burner possibly blocked)
78	Too large deviation of the oxygen level in the waste gas from the desired value (burner possibly dirty)
79	O ₂ sensor feed level was greater than the limits
80	O ₂ sensor feed level was insufficient