

RS TURBOFLOW

PLATE HEAT EXCHANGERS



OPERATING & MAINTENANCE MANUAL

MODELS - DN32: S020+ S040+ S080+
DN65: S125+ S180+
DN150: S400+ S600+ S900+

DN50: S070+ S160+ S260+
DN100: S300+ S450+ S700+
DN200: S650+ S990+



HIGH EFFICIENCY BOILER-PLANT

ATLANTIC 2000 - boilerplant sales ACM ATLANTIC - commissioning and maintenance ATLANTIC 4422 – spares
Atlantic 2000 Registered in England Company No: 1477687 Vat Reg No: 306 0653 89
PO BOX 11, ASHTON UNDER LYNE, OL6 7TR T: 0161 621 5960 E: technical@atlanticboilers.com www.atlanticboilers.com

RS Plate Heat Exchanger Installation, Operation and Maintenance



Every RS heat exchanger is pressure tested before delivery & is ready for installation.

A – To avoid damage to the PHE & prevent injury to personnel it is better to move the unit as shown in Fig A

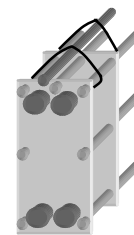

Fig A

B - The PHE should be installed in the upright position. Make sure you have enough space to open the PHE for any inspections or repairs. Space should be provided at the sides and ends to allow work to be carried out - a minimum of 300mm. as shown in Fig B

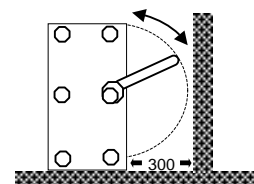

Fig B

C – Piping should be connected according to inlet/outlet labels

Entrata –inlet I – *primary circuit*
Uscita – outlet II – *secondary circuit*

as shown in Fig C

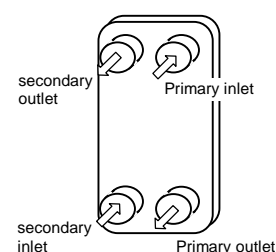

Fig C

D – When connecting threaded connections, always use two wrenches or spanners to avoid breaking of the gasket seals.

START UP

1. Close all isolating valves – no pumps in operation
2. Check for the desired working pressure
3. Fill & vent the secondary circuits, valve by valve through the plate heat exchanger. **Open valves gradually to prevent shock on the plates.**
4. Having filled the secondary circuit, close the valves again
5. Repeat the procedure on the primary circuit, again without all pumps running. Vent the circuits through the safety valve levers. On completion close the valves.
6. Bring on the secondary pump, at the same time opening up the valves gradually to allow smooth flow.
7. Repeat the procedure for the primary pump.
7. After 30/45 minutes stop the plant. Then isolate, open & inspect all strainers for sediment. Clean & repeat as necessary until the strainers remain clear.
8. Top-up & commence automatic control & operation.

MAINTENANCE

Visual inspection of the plate heat exchanger, cleaning of strainers & flushing of the system is all that is required for maintenance. If the plate heat exchanger develops a leak then isolate & drain down the plate heat exchanger and tighten all the spacer bolts with equal turns until they become tight, the correct amount of tightening can be checked by contacting ATLANTIC 2000. Open valves until hydraulic working pressure is reached. If the plate heat exchanger continues to leak, a new set of gaskets is available from ATLANTIC 4422, tel: 0161 621 5963.

www.atlanticboilers.com

EMAIL info@atlantic2000.co.uk

Tel 0161 621 5960 Fax 0161 621 5966 Box 11, Ashton-under-Lyne, OL6 7TR

1 - GENERAL

1.1 - Preface

Your heat exchanger will give you full satisfaction provided you maintain it well, in full, and diligently.

- Be sure to keep the following documents in a safe place:
 - 1) this owner's and servicing manual (supplied with the heat exchanger);
 - 2) the CE certificate of conformity, if necessary;
- Your plate heat exchanger has a limited range of temperatures and pressures. As it is highly sensitive to sudden changes in these parameters, all precautions must be taken to avoid operating outside the limits indicated on the nameplate.
- Excessive temperatures will damage the gaskets (install the appropriate safety thermostats, etc.).
- Excessive operating pressures or differential pressures will damage the gaskets and plates (install the appropriate safety valves, etc.).
- Plate heat exchangers are highly sensitive to pressure surges.

Accordingly, the control must be designed to prevent this occurring and **QUARTER-TURN VALVES MUST NOT BE INSTALLED ON ANY OF THE CIRCUITS.**

- Given the large number of gaskets, leaks may occasionally occur. To protect against this eventuality, install protective screens if dangerous fluids are used or the temperatures rise to above 60°C.
- Atlantic may not be held liable for any damage or injury resulting from failure to follow the instructions in this manual.
- Atlantic is not liable for any consequences that may result from the accidental mixing of the fluids used in the heat exchanger.

1.2 - Regulations

- Official inspections: some heat exchangers must be regularly inspected by official bodies. It is the operator's responsibility to organise these inspections directly with the competent bodies. The dossier sent to our principal must therefore be kept in a safe place.

- The heat exchanger risk category according to the European Pressure Equipment Directive (PED) currently in force, is indicated on the identification nameplate.

- You must make sure that the entire system complies with the directives and legislation in effect in the country of operation.

- This heat exchanger must not be used for purposes other than those stated on the order documents. In particular, do not use fluids other than those specified at the time of ordering.

- Scrupulously comply with the operating conditions set out in the order documents. They were used to determine the equipment category set out in the European Pressure Equipment Directive. Atlantic shall not be held liable for any or consequential or incidental damages resulting from failure to do so.

- Atlantic must be notified of any changes in the operating conditions and will inform you of the procedure to follow.

1.3 - Warranty

- The warranty is valid only if the heat exchangers operate under the conditions for which they were initially designed.

- The warranty can be applied only if pressures and temperatures of the fluids can be measured on the heat exchanger's inlets and outlets.

- Spare parts are warranted only if the storage instructions have been followed (see the section STORAGE). The plate pack is surrounded by a strap (the so called warranty seal) that, if left unbroken, is proof that the exchanger has never been disassembled. Removing this strap, without written authorization of the manufacturer, will always void the warranty.

1.4 - Residual risks: damage > cause (prevention) **POSSIBLE BODILY INJURY**

- Unit tipover > Failure to follow the handling or anchoring instructions (the unit has a very high centre of gravity; follow the rigging instructions; anchor the unit to the floor).

- Burns > Direct contact with the unit while in operation or with scalding or corrosive fluids following a leak (cut off the supply to the unit; set

up barriers around it; wear PPE = Personal Protective Equipment).

- Cuts > Handling the plates without protective glove (wear PPE).
- Injury > Caused by pressure, affecting in particular the eyes or bare skin (wear PPE and prohibit access by unauthorised personnel).
- Poisoning > Skin contact with, or inhalation of, a dangerous fluid (wear PPE and use safety equipment).
- Poisoning > Combustion of the gaskets (never dispose of the gaskets by burning them).
- Poisoning > Accidental mixing of circulating fluids resulting in the release of hazardous fumes (make sure that resulting mixture is not dangerous).

COMMON TYPES OF EQUIPMENT DAMAGE

- Gasket destruction > One fluid circulated at a high temperature (always circulate the cold fluid FIRST and the hot fluid LAST).
- Gasket destruction > Sudden changes in pressure or temperature (monitor the control).
- Gasket destruction > Overrun of operating conditions (check the operating parameters).
- Plate destruction > Corrosion or erosion (check the type and speed of the fluids being circulated; install filters).
- Plate destruction > Overpressure (check the pressure of the fluids; watch out for sudden or frequent changes in pressure or temperature).
- Plate destruction > The heat exchanger has frozen (either make sure that the room temperature does not drop below 0°C while the system is not in use or drain the circuits).
- Leaks > The tightening dimension is wrong (check the tightness of the plate pack).
- Leaks > The frame or a number of plates are dented (contact Atlantic).

- Pollution > Leak of a dangerous or polluting fluid (have spill trays on hand).

- Explosion > Accidental mixing of circulating fluids resulting in the release of explosive fumes (make sure that resulting mixture is not dangerous). Prohibit access to the system by unauthorised personnel.

Make sure that servicing technicians have the proper training.

Keep this manual near the heat exchanger.

1.5 - Receiving the unit

- Upon delivery, check the contents for missing or damaged items. Note any missing or damaged items on the delivery slip. Inform Atlantic of said damaged or missing items by registered letter within three days of delivery and forward a copy to Atlantic.

- The front of each heat exchanger is fitted with a nameplate listing a serial number. Please state this number in all correspondence.

1.6 - Handling

- The handling and unloading equipment is for the account of the recipient.

- Follow the rigging instructions (Figures 1a, 1b and 2).

- Use web slings (no metal chains). Insert them in the designated notches on the head and follower.

- The unit's weight is stated on the delivery slip and the shipping note.

- When moving and handling the heat exchanger, make sure that it is properly supported and secured as its high centre of gravity may cause it to tip over easily.

- Never lift the unit by its guide rails, compression bolts or pipes, as doing so can cause them to bend.

- Shield the plates from impacts as they could cause irreparable leaks.

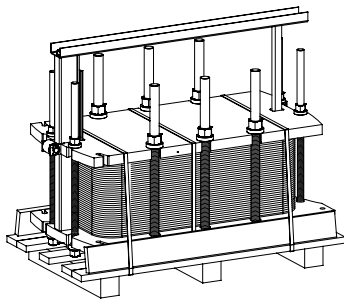

Fig. 1a

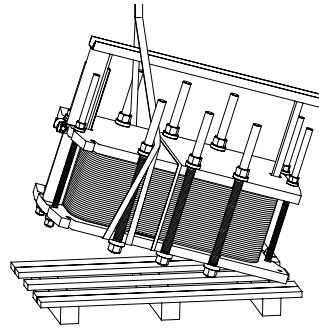

Fig. 1b

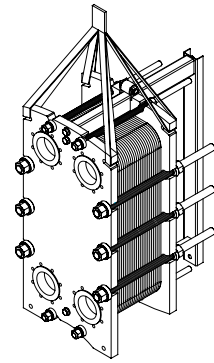
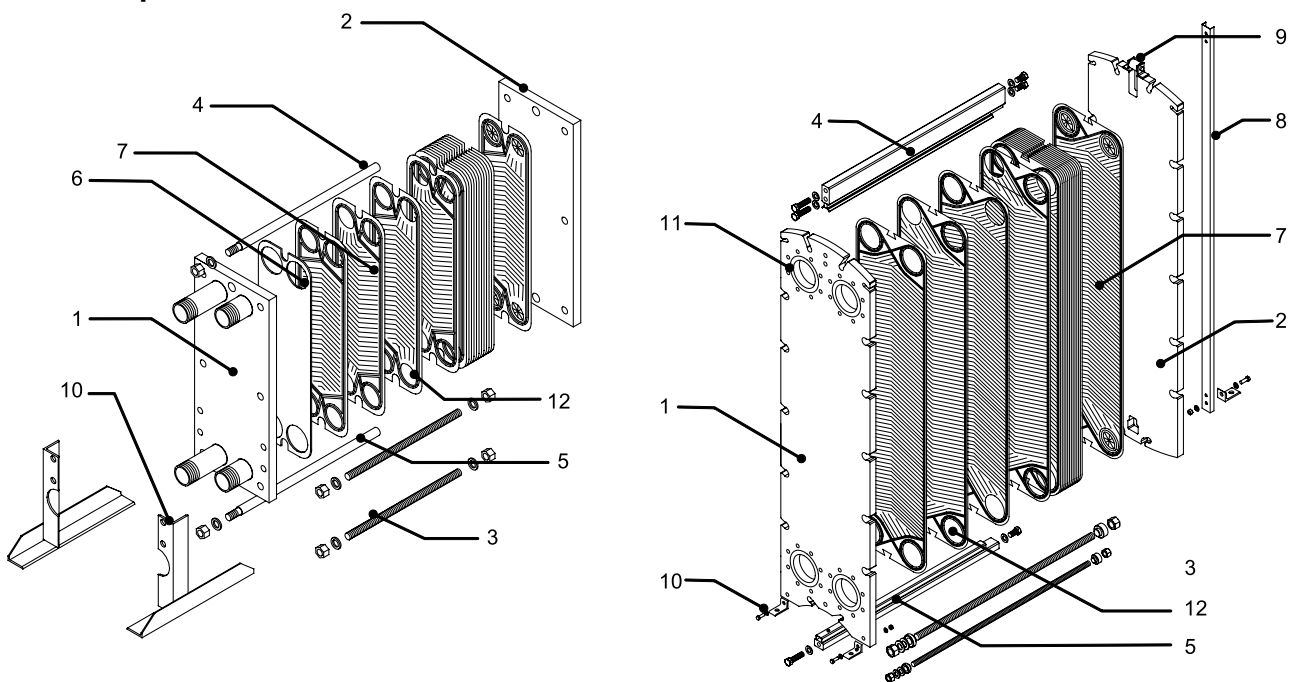

Fig. 2

1.7 - Intended use

- Our gasketed plate heat exchangers are designed to heat or cool fluids by means of heat transfer through indirect contact with another fluid.
- The specific operating conditions of your heat exchanger's are set out in the contractual documents agreed throughout the equipment's supply.
- If the heat exchanger will be used with fluids intended for human consumption, please contact our consultants.
- The heat exchangers and their components must never be used for purposes other than those for which they were initially designed.

1.8 - Description



- | | | |
|--------------------------|----------------------|---------------|
| 1 - Frame plate | 5 - Guiding bar | 9 - Roller |
| 2 - Pressure plate | 6 - Aluminium Spacer | 10 - Feet |
| 3 - Tightening bolts | 7 - Plates + gaskets | 11 - Liners |
| 4 - Guiding/Carrying bar | 8 - Column | 12 - Porthole |

1.9 - Nameplate

- Stuck to the frame plates.

MANUFACTURING YEAR Année de construction	

MODEL Modèle	



SERIAL No. Série	

DATE Date	

REF. Réf.	

NOTES Notes	

ALLOWABLE MIN. / MAX. TEMPERATURE (TS) Température min. / max. admissible	
-----	/ °C
ALLOWABLE MIN. / MAX. PRESSURE (PS) Pression min. / max. admissible	
-----	/ bar
TEST PRESSURE (PT) Pression d'épreuve	
-----	bar
VOLUME OF EACH CIRCUIT Volume de chaque circuit	
-----	l
97/23/CE PED CLASSIFICATION Selon DESP 97/23/CE	

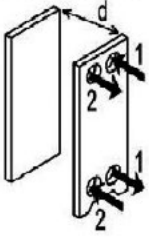
  	
REFER TO User and Maintenance Manual	

TIGHTENING MEASURE (d) Cote de serrage	
MAX.	mm
MIN.	mm
WEIGHT (EMPTY) Poids à vide	
-----	kg
Made in ITALY	

- **MANUFACTURING YEAR:** Year of manufacture.
- **MODEL:** Heat exchanger model and product configuration.
- **SERIAL No.:** Production number, to identify your heat exchanger.
- **DATE:** Date of manufacture.
- **REF.:** Eventual notes and/or different references.
- **ALLOWABLE TEMPERATURE MIN. / MAX. (TS):** Minimum and maximum allowable temperatures.
- **ALLOWABLE PRESSURE MIN. / MAX. (PS):** Minimum and maximum allowable pressure, in bar.
- **TEST PRESSURE (PT):** Test pressure, in bar.
- **VOLUME:** Total capacity of the heat exchanger, in litres.
- **PED CLASSIFICATION:** Risk category of the heat exchanger (hazard group and physical state of the fluid).
- **CE MARKING:** Only the heat exchangers classified in PED risk category I, II, III or IV can be CE marked. The identification number of the Notified Body will appear near to the CE Mark symbol for heat exchangers classified in risk category II, III or IV.
- **CIRCULATION:** 1 indicates the inlet and outlet of the primary loop. 2 indicates the inlet and outlet of the secondary loop.
- **TIGHTENING MEASURE:** Minimum and maximum tightening dimension (d) between the plates, in mm.
- **WEIGHT (EMPTY):** Empty weight of the heat exchanger, in kilograms.

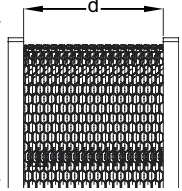

2 - STORAGE

- Store the heat exchangers in a dry room protected from the weather and maintained at a temperature between +5°C and +35°C.
- The heat exchangers must be placed on blocks dimensioned and adjusted to ensure adequate stability and levelness, on a floor protected from caving in. Make sure that they do not touch each other and that they are not in direct contact with the floor and any walls.
- Protect them from impacts, dust and from the risk of liquid or solid deposits and make sure that nothing is placed on them.
- Do not remove the protection on the end of the pipes until you are ready to make the hydraulic connections.
- All unused spare parts must be stored away from damp, light, and dust, and protected from impacts.
- Gaskets and gasketed plates must be stored in appropriate boxes at a temperature of between 10°C and 30°C. Maximum shelf-life: 12 months.

3 - INSTALLATION

Always read this guide carefully before working on the unit and keep it in a safe place for future reference.

3.1 - Choice of location

The intended location of the unit should be fully accessible so as to ease servicing and maintenance operations and allow easy removal of the plates from the side of the unit (Fig. 3). Adequate clearance must be left in front of the safety and control devices.

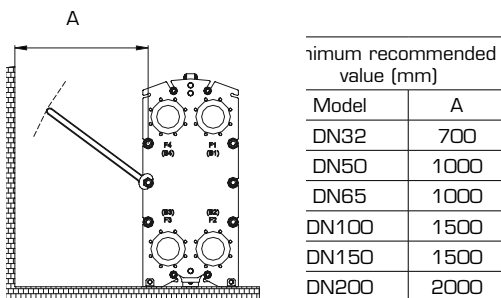

Fig. 3

3.2 - Installation recommendations

- Atlantic plate heat exchangers have a limited operating pressure and temperature range. Install all the necessary safety devices to prevent overrunning the limits specified on the order documents. Approval to use the plate heat exchangers at higher conditions must be obtained from Atlantic.

It is recommended to fit pressure and temperature test points near the unit.

- Make sure that the heat exchanger is compliant with the safety rules in force on the site of use (explosive atmosphere, etc.).
- Affix appropriate visual warning sign wherever the surface temperature above 60°C or below 0°C.
- If the heat exchanger is to be installed on framework, the 35 structure must be designed to withstand the weight of the

exchanger when in operation (filled) and with its accessories.

- If necessary, affix the hazard symbol corresponding to the fluid in accordance with applicable standards.
- Take all appropriate steps to mitigate the effects of any significant human, environmental or financial consequences of failure.
- Make sure that the heat exchanger is always installed vertically, stable, and secured using all its anchorage points. If necessary, fit additional anchors suitable for the foreseeable stresses.

- Install drains and vents, shut-off valves, and fill and drain valves on the pipes so that the heat exchanger can be serviced without disrupting the system.

- In the event of seasonal use, drain the heat exchanger completely to prevent any risk of freezing or corrosion if a corrosive fluid is used.

- If accessories are installed on the heat exchanger, refer to their specific instructions.

3.3 - Hydraulic connections

- To keep the insides of the pipes clean, do not remove the seals on their ends until you are ready to make the hydraulic connections.

- The insides of the pipes must be free of all foreign matter (sand, welding slag, other solid matter, etc.) that could damage the plates and gaskets.

- Filtration: If the fluids to be circulated through the heat exchanger contain suspended matter, a filtration system of up to 500 µm must be installed.

- Check the tightening dimension specified on the nameplate. Refer to section 5.7 if retightening is needed.

- Make the hydraulic connections as instructed on the nameplate on the frame or on the plate arrangement drawing.

- Never insert foreign matter into the circuit.

- No strain should be placed on the pipes (weight of connected pipes, expansion, vibrations etc.).

- If threaded couplings are used, do not apply the tightening torque to the threaded nozzles.

- Threaded nozzles are not welded to the fixed head. To avoid damaging the first gasket, hold the threaded nozzles in place with pliers and screw on the pipes (Fig. 4).

- If the ports on the fixed head are fitted with protective built-in linings, the linings must be sufficiently compressed so that the head and the counter-flange are separated by a 2 mm gap (tightening any further will damage the linings).

- In the case of a multi-pass heat exchanger (fluid inlet and outlet ports on both ends): install an expansion fitting or a horseshoe loop and use detachable pipes so that more plates can be added and the movable follower can be removed.

Fig.4

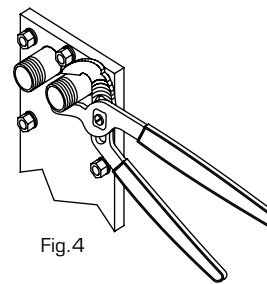

Fig.4

3.4 - Insulation and protection accessories

TF insulation

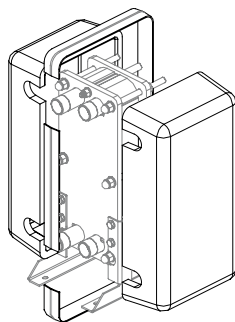
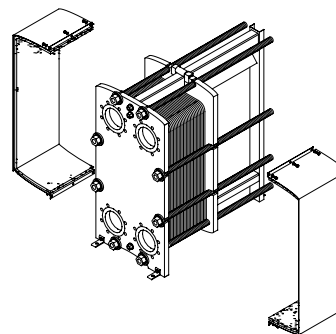
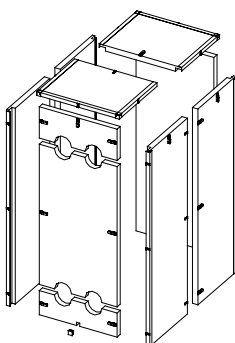

Plate pack protection



PB insulation



Drip tray

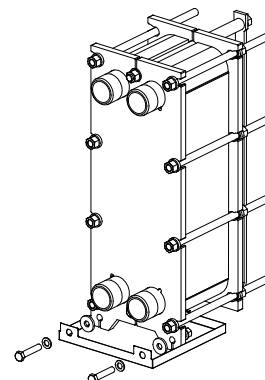

4 - OPERATION

4.1 - Commissioning

- Make sure that the heat exchangers do not operate under conditions that are severer than the design conditions (pressure, temperature, flow rate, fluid type).
- Make sure that the tightening dimension matches that shown on the nameplate. Never tighten beyond this dimension.
- Open the valves slowly to avoid water hammering and thermal shock. Sudden changes in temperature or pressure as well as sudden inrushes of hot fluid in a cold unit (or vice versa) may damage the gaskets and plates and cause leaks.
- Make sure that the heat exchanger is not subject to vibrations or frequent short cycles.
- Purge air from the two circuits completely after circulating the fluids. Air left inside the circuits may cause product overheating, reduce the exchanger's efficiency and increase the risks of corrosion.

4.2 - Post-commissioning tests

After running the system for one hour:

- Check for signs of leaks. Weak flow rates, however, are normal during commissioning.
- Check the pressures and temperatures of all the fluids being circulated.

5 - MAINTENANCE

- All maintenance operations must be carried out by qualified, trained personnel.
- The heat exchanger may not be altered in any way without Atlantic's consent.
- As the maintenance intervals depend on a multitude of parameters (fluids, temperatures, etc.), the frequency of preventive maintenance is left to the operator's judgment. Nevertheless, a maintenance inspection is recommended at least once a year.
- Periodically check the condition of the corrosion protection coatings and apply touch-ups as needed.

5.1 - Preventive maintenance

- Our experience shows that, when used under normal operating conditions, gasketed heat exchangers have a service life of over 10 years. We advise against opening them too often.
- Inquire about applicable environmental standards and prevailing legislation, particularly regarding the frequency of checks and what to do in the event of a leak.
- Once a year, test the operation of all safety devices, check the condition of the insulation, look for signs of external corrosion and test the pressure on the heat exchanger outlet.
- Record all periodic checks and problems in the maintenance log.

Short-term storage (< 3 months)

- 1) Gradually lower the pressure in each circuit.
- 2) Turn off the pumps and close the shut-off valves, starting with the hot circuit and then the cold circuit.
- 3) Let the heat exchanger cool to room temperature.
- 4) Completely drain the heat exchanger and close the drain and vent valves.

Long-term storage (> 3 months)

Carry out the above steps as well as the following:

- 1) Flush the heat exchanger circuits with water to remove all residue.
- 2) Loosen the nuts on the tie bolts to reduce the compression on the gaskets.
- 3) Apply a rust preventive on the tie bolts.
- 4) When recommissioning the heat exchanger, lubricate the tie bolts and guide bars then go to section 4.1.
- 5) Retighten the plates to the dimension shown on the nameplate.

5.2 - Disassembly

- Breaking the special quality strap around the heat exchanger will void the warranty. You must obtain Atlantic's written permission in order to remove the strap.
- Store the plates on a flat, clean surface away from ferrous particles and dirt.
- For easier reassembly, stack the plates in the order of assembly or number them.

- Separate the plates with care, paying particular attention to the fastening of the Plug-In® gaskets; the gaskets tend to stick to the plates after a period of prolonged operation at high temperatures. Gaskets that retain their original properties may be reused.
- Never mix new and old gaskets as the difference in elasticity will result in overcompression of the new gaskets and reduce their service life.

Procedure

- 1) Disconnect the pipes at the back of the frame (multi-circuit units).
- 2) Clean and lubricate the tie-rods.
- 3) Measure the tightening dimension.
- 4) Loosen all the nuts in the order shown in Figure 11 pull back the movable follower and carefully remove the plates one by one so as not to damage them. Wear protective gloves while doing so as the edges of the plates are sharp.
- 5) Remove the gaskets by lifting the tabs out of their slots on the edges of the plates.
- 6) Clean the heat exchanger.

NUTS & BOLTS SIZE	DN 32			DN 50			DN 65 (**)		DN 100			DN 150			DN 200	
Model	S020+	S040+	S080+	S070+	S160+	S260+	S125+	S180+	S300+	S450+	S700+	S400+	S600+	S900+	S650+	S990+
PS6 frame tightening bolts (1)	M12			M16			-	M16 M20	-			-			-	-
Spanner size	19			24			-	24 30	-			-			-	-
PS10 frame tightening bolts (1)	M14			M20			M20		M24 / M33			M24 / M33			M33 / M39	M33
Spanner size	22			30			30		36 / 50			36 / 50			50 / 60	50
PS16 frame tightening bolts (1)	M14	M16	M20			M20	-	M24 / M33			M24 / M33			M33 / M39	M33	
Spanner size	22	24	30			30	-	36 / 50			36 / 50			50 / 60	50	
PS25 frame tightening bolts (1)	M16			M20			-	-	M24 / M33		-	-			-	-
Spanner size	24			30			-	-	36 / 50		-	-			-	-
Carrying bars frame plate (2) / pressure plate (3)	M12			M16			M20		M18			M20			M20	
Spanner size	19			24 (*)			30		27			30			30	
Guiding bars frame plate (4) / pressure plate (5)	M12			M16			M20 / M16		M18			M20			M20	
Spanner size	19			24 (*)			30 / 24		27			30			30	
Feet (6)	M10			M16			M16		M16			M16			M16	
Spanner size	17			24			24		24			24			30	

(*) FRAME WITH FLANGED CONNECTIONS

14 Allen key

(**) FRAME WITHOUT LATERAL EXTRECTION (up to beginning 2012)

Carrying bars (2) and (3):
S125+ M22 / S180+ M20
Spanner size:
S125+ 32 / S180+ 30

Guiding bars (4) and (5):
S125+ M22 / S180+ M20
Spanner size:
S125+ 32 / S180+ 30

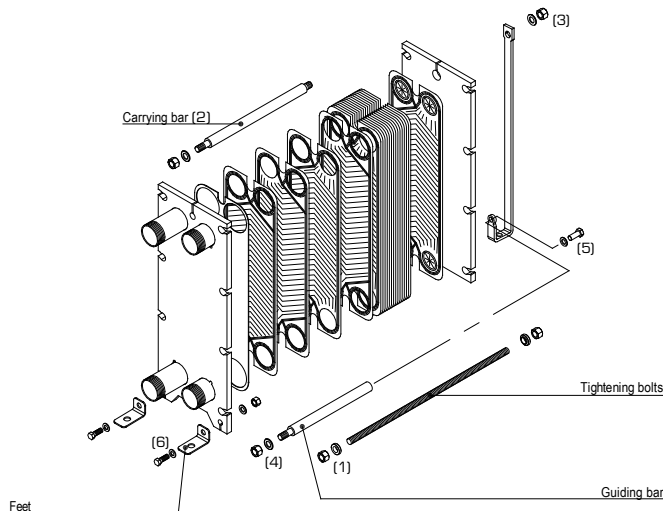

5.3 - Manual cleaning

- Always wear safety glasses and protective gloves and follow the instructions for the cleaning products used.
- Dispose of wastewater in accordance with prevailing environmental protection regulations.
- Never use metal tools, abrasives, or corrosives.
- Use a soft, non-metallic brush and suitable detergent.
- A pressure washer may be used provided the necessary precautions are taken to avoid damaging the gaskets.
- Soak the plates in a detergent solution if they are coated with thick deposits.
- Thoroughly rinse the plates, and especially the gaskets, in cold or lukewarm water.
- Degrease the plates before reinstalling them, especially if one of the fluids circulated is a lubricant (e.g. oil).
- Carefully check the condition and sealing surfaces of the gaskets, the flatness of the plates, and the overall cleanliness.

5.4 - Clean in place (CIP)

- CIP is recommended if the heat exchanger requires frequent cleaning or is hard to disassemble.
- CIP can be performed provided it is impossible for particles to build up inside the heat exchanger. Likewise, if there is a risk of the surfaces of the plates being damaged by particles, manual cleaning should be performed.
- The CIP procedure must be determined with a specialised firm when the system is designed.
- After the first few cleanings, it may be necessary to open the heat exchanger in order to check the degree of cleanliness, adjust the cycle time and determine the best product concentrations.

Procedure

- 1) Completely drain all the circuits (if this is not possible, run fresh water through the circuits until the process fluids have been completely flushed out).
- 2) Clean with fresh water (with a low chloride content for the stainless steel plates) at a temperature of around 40°C to eliminate all traces of the process fluids. Run this water in the opposite direction of normal operation. An even better result can be obtained by running the water alternately in one direction and then the other (this is advised for steam applications or to eliminate residues such as fibres and particles). The use of filters upstream of the heat exchanger will reduce the need for this.
- 3) Completely drain the water from the circuits and connect the CIP unit. Do not let the solution sit in the exchanger.
- 4) For even better cleaning, use a centrifugal pump installed between the CIP and the heat exchanger. Circulate the detergent solution in the direction opposite that of the fluids so as to eliminate all traces of dirt.
- 5) Circulate a quantity of detergent solution at above the nominal mflow rate but without exceeding the maximum allowable flow rate (determined by the nominal diameter).
- 6) Thoroughly flush both circuits with fresh water.

5.5 - Detergents

- Never use hydrochloric acid (HCl) or chlorinated compounds with stainless steel.
- Never use phosphoric acid with titanium.
- Suitable detergents may be obtained from specialised firms. Specify the plate and gasket types to obtain a detergent that will not remove the protective oxide layer on the plates or destroy the gaskets.
- Nitric acid (HNO₃) and sodium hydroxide (NaOH) may be used to clean stainless steel and titanium plates.
- Polyphosphates may also be used.

Descaling

- Use a nitric acid (HNO₃) or citric acid solution: 1.5% concentration by weight, max. temperature 65°C (1.5% by weight corresponds to 1.75 l of 62% HNO₃ for 100 litres of water) or a polyphosphate solution (NaPO₄ or Na₃PO₄): 1.5% max. concentration by weight, max. temperature 50°C.

Degreasing

- Degrease stainless steel or titanium plates with a sodium hydroxide (NaOH) solution: 1.5% max. concentration by weight, max. temperature 65°C (1.5% by weight corresponds to 3.75 l of 30% NaOH for 100 litres of water).
- Do not use hydrochloric acid or water with a chloride content of over 300 ppm to clean stainless steel plates.
- Do not use phosphoric acid to clean titanium plates.

Deposits: Calcium

Recommended detergents: 4% nitric acid solution at 60°C max. - 4% citric acid solution at 60°C max.

Oils and greases

Recommended detergents: paraffin or kerosene (as these fluids may damage NBR and EPDM gaskets, limit the contact time to no more than 30 minutes)

Sludges, metal oxides

Recommended detergents: 8% nitric acid solution at 60°C max. - 4% citric acid solution at 60°C max.

Organic matter

Recommended detergents: 2% sodium hydroxide solution at 40°C max.

5.6 - Liquid penetrant testing

- Corrosion, galvanic coupling and erosion can create holes in the plates. As such damage is not always visible to the naked eye, we recommend performing liquid Atlantic tests to check for holes or microcracks. Atlantic technical support team can advise you on the appropriate products.

5.7 - Gasket replacement

- Before starting, check the manufacturing date of the gaskets, printed on the relevant date stamp (Fig.5). Please note that the gaskets must not be stored for more than 6-12 months (see chapter 2 - STORAGE).

- Remove the old gasket without using cutting tools, which could irreparably damage the plate.

- Make sure that the plate and gasket are thoroughly clean and dry alongside the gasket slot.

5.7.1 - Plug-In® Design gaskets

- Press the gasket onto the plate (Fig. 6), making sure that the leak detector vents, "A", are facing up and check that the Plug-In® tabs are hooked into their respective notches (Fig.7). Make sure that the gasket is properly seated in its notch, then turn the plate over to check again that all the Plug-In® tabs are correctly in place.

5.7.2 - Plug-In® Design gaskets which may require the use of glue

- Plug-In® Design gaskets, for initial plates, intermediate turning plates (for multi-pass heat exchangers only) and final plates, may require a limited use of glue. These types of plates, complete with gaskets mounted at the factory, can be supplied as spare parts. Alternatively, for the substitution of the gaskets, proceed as described below.

A: Leak detector vents are notches in the surfaces of the gasket sections around the portholes which vent any leaks to the atmosphere so that they can be detected.

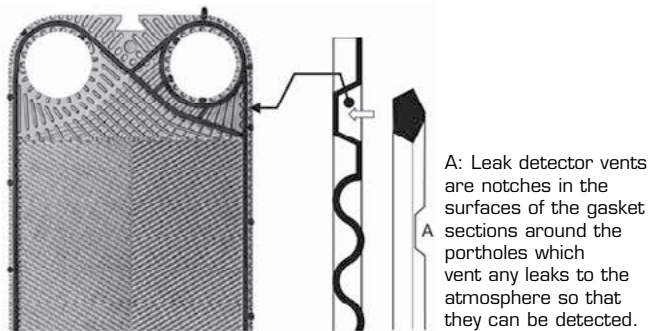

Fig.6



Fig.7

Initial plate

Cut two gaskets along the vertical axis and use the two parts with sealing rings inside the holes (Fig.8) to form a complete initial gasket. Discard the other two halves.

- The half of the gasket for which it is possible to correctly place all Plug-In® tabs in their corresponding notches, can be mounted as described in 5.7.1.
- On the other half, use shears to remove all the Plug-In® tabs and, if present, all the connecting bridges between the diagonal and the sealing ring (Fig.9 b). So, following the procedure described in point 5.7.3, attach the gasket, excluding the sealing rings.

Intermediate turning plate

(for multi-pass heat exchangers only) and end plate 1. Models equipped with Plug-In® tabs inside the sealing rings: using shears, cut the Plug-In® tabs inside the sealing rings (Fig. 9 c) corresponding to the closed holes only. Then, following the procedure described in point 5.7.3, attach only the connecting bridges between the diagonal and the ring.

2. Models without Plug-In® tabs inside the sealing rings: no cutting is necessary; proceed as described in point 5.7.1.

NOTE: On some models it might be necessary to remove all the Plug-In® tabs (not only those inside the sealing rings). In this case, if permitted, remove the entire gasket.

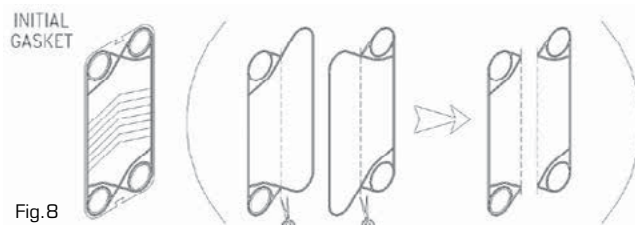

Fig.8

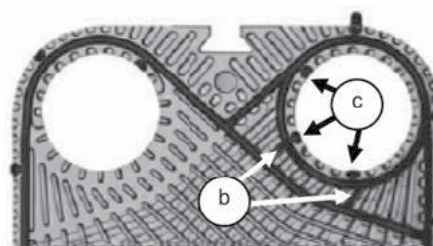

Fig.9

- The half of the gasket for which it is possible to correctly place all Plug-In® tabs in their corresponding notches, can be mounted as described in 5.7.1.
- On the other half, use shears to remove all the Plug-In® tabs and, if present, all the connecting bridges between the diagonal and the sealing ring (Fig.9 b). So, following the procedure described in point 5.7.3, attach the gasket, excluding the sealing rings.

NOTE: For the DN200 models it is recommended, if permitted, to attach the entire gasket.

5.7.3 - Gluing

- Using the appropriate epoxy glue (supplied as a spare part, on request), spread a strip of glue (2-3 mm) onto the plate in the gasket slot.
- Leave to dry for 5 minutes in a suitably ventilated room, then position the gasket on the plate, making sure that it is perfectly contained in the slot and that there is no excess glue escaping from the slot.
- Place a counterweight on the glued plates (without deforming the plastic), ensuring that the whole gasket is evenly compressed for at least 2 hours.

N.B. Some particular standards (e.g. ACS Attestation de Conformité Sanitaire) may prohibit direct contact between fluid and glue. If this is the case, do not glue the parts of the gasket which could come into direct contact with the fluid.

WARNING: Always follow the mandatory general standards for personal protection, in particular: avoid contact with the eyes, use an appropriate protective mask to protect against inhalation hazards and wear gloves.

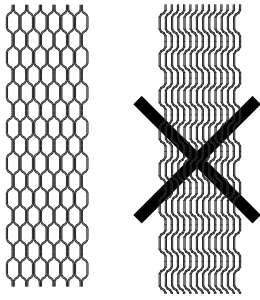

Fig.10

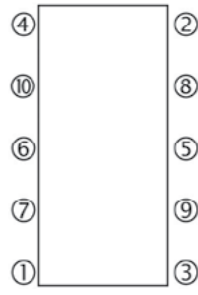

Fig.11

5.8 - Reassembly

- Before reassembling the heat exchanger, make sure that all the plates and gaskets are clean and free of grease.
- When arranged correctly, the stacked plates form a honeycomb pattern (Fig.10).
- The order of assembly and the plate direction are specified on the plate arrangement drawing

Procedure

- Starting from the frame plate, assemble the plates on the bar one by one with the gaskets facing the frame plate.
- Clean and lubricate the tie-rods, position them on the frame, then tighten the nuts gradually and evenly in the order indicated in Fig. 11 until the correct dimension is obtained between the plates (tightening dimension), as specified on the nameplate. Check that this dimension is the same on each side. Overtightening may irreversibly distort the plates. If you feel it is necessary to tighten beyond the recommended dimension, contact Atlantic to obtain advice.
- It is recommended to perform a pressure test after all maintenance on the plates and gaskets in order to check the heat exchanger's internal and external tightness. The maximum pressure for each circuit should be equal to the operating pressure and should never exceed the rated pressure (PS) specified on the nameplate. The recommended testing time is at least 10 minutes. Nevertheless, it remains the user's responsibility to check national standards and local codes affecting such a test. If different test conditions are required, please note that the heat exchangers

should never be tested at pressures greater than the test pressure (PT) specified on the nameplate and that the pressure differences between the two circuits during testing should never be higher than the maximum allowable differential pressure.

- If a leak occurs, lower the pressure then retighten the nuts and repeat the test. If the leak persists, check the gaskets and plates for signs of wear, damage or dirt. If necessary, replace the gaskets.

5.9 - Plate types

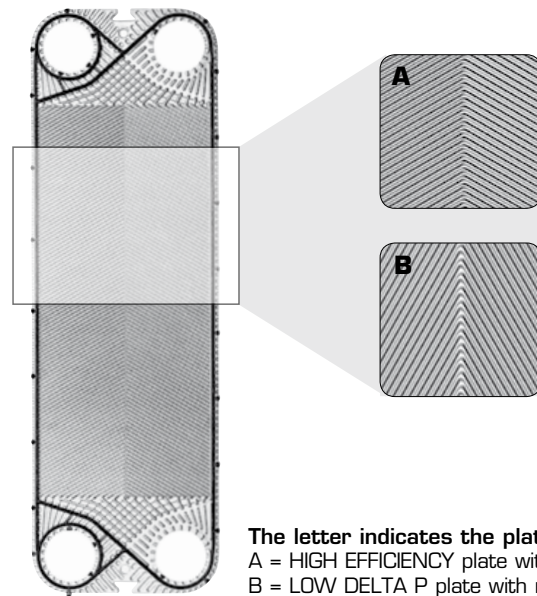

The letter indicates the plate type:
 A = HIGH EFFICIENCY plate with wide chevron pattern
 B = LOW DELTA P plate with narrow chevron pattern

PORT HOLES FOR PLATES ON SINGLE-PASS UNITS

DESCRIPTION =>	ODD INITIAL	EVEN INTERMEDIATE	ODD INTERMEDIATE	ODD FINAL	PORT HOLES POSITION
PARALLEL FLOW					
CODE =>	1234	1234	1234	0	

PORT HOLES POSITION FOR DEVIATION PLATE

1,2,4	1,3,4	1,2,3	2,3,4	1,4	2,3	3	3	
-------	-------	-------	-------	-----	-----	---	---	--

Drilling the collectors. Code which indicates the position and the open or closed status of the collectors.

1234 = Open 0 = Closed

e.g.: 1204: indicates that porthole No. 3 is closed.

5.10 - Arrangement examples

Legend:

- 1: Frame plate
- 2: Pressure plate
- 3: Initial plate
- 4: End plate
- 5: Intermediate plates
- 6: Turning plate

Single-pass/Single-pass arrangement (1-1)

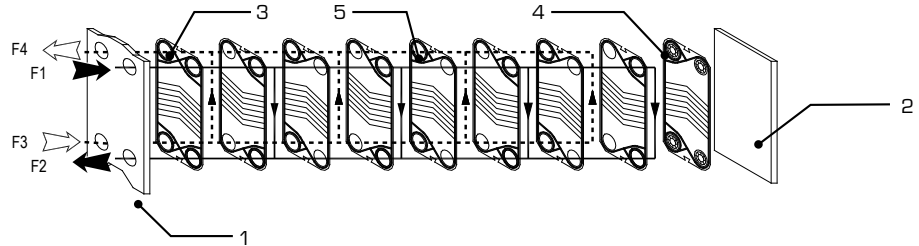

Two-pass/Two-pass arrangement (2-2)

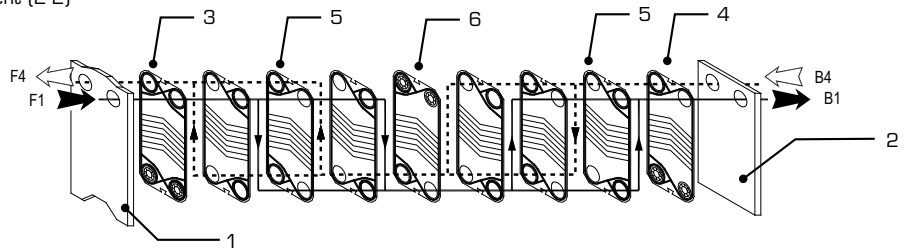

Mixed plate pack - High performance plate > 50%

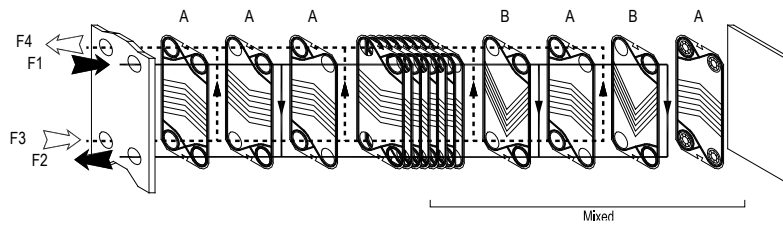

Mixed plate pack - High performance plate = 50%

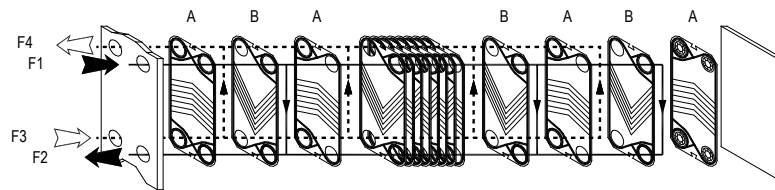

Mixed plate pack - High performance plate < 50%

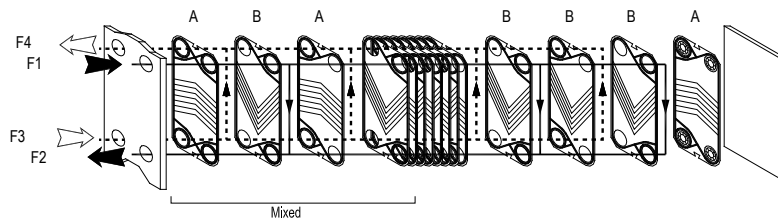

5.11 - Increasing the transfer area

It is possible to add an even number of extra plates to an existing heat exchanger, provided you:

- Check the maximum plate capacity of the heat exchanger.
- If the length is insufficient, provide new carrying bars and threaded rods.
- Replace the nameplate and the plate arrangement drawing with the new ones provided by CIPRIANI.
- Leaks often occur when plates with new gaskets and plates with old gaskets are used together (due to difference in toughness). We therefore strongly recommend replacing all worn gaskets with new ones.

5.12 - Spare plates

Plates may be replaced individually or altogether. In this last case, however, it is recommended to replace all the gaskets (see the previous section).

- If only a few plates are replaced, indicate the sequence of the plates to be replaced shown on the plate arrangement drawing.

5.13 - Troubleshooting

FLUID LEAKS BETWEEN PLATE PACK AND FRAME PROBLEM

Leak detected at the bottom of the pack.

POSSIBLE SOLUTIONS

- Make sure that all the bolts are correctly tightened.
- Make sure that there is no mechanical stress on any of the connections.
- Reposition or replace the gasket on the initial or end plate.
- Check the internal surface of the fixed head for defects.
- Make sure that there are no foreign bodies between the initial plate and the fixed head.
- Test the initial/end plate for signs of damage (cracks, holes).

FLUID LEAKS BETWEEN CONNECTIONS AND FRAME PROBLEM

Fluid leaks where a connection passes through the fixed head.

POSSIBLE SOLUTIONS

- If welded connections are used, check the condition of the welds.
- If cracks are found, contact your Atlantic consultant before attempting any repairs.
- If other connections are used, contact your Atlantic consultant.

FLUID LEAKS FROM THE PLATE PACK PROBLEM

Leak detected from plate pack.

POSSIBLE SOLUTIONS

- Measure the tightening dimension and check it against the nameplate. Tighten if need be.
- Mark the area around the leak with a felt-tip pen then open the heat exchanger and inspect the area.
- Check the sequence and alignment of the plates.
- Check the condition of the gaskets (correct position, overall condition, elasticity). Reposition or replace the gaskets as needed.

INTERNAL LEAKS WITH mixing of fluids

Contact Atlantic as quickly as possible.

PROBLEM

The fluids in the heat exchanger are mixing together at the unit's outlet.

POSSIBLE SOLUTIONS

- Make sure that the hydraulic connections are correct.
- Disassemble the heat exchanger and inspect the entire surface of each plate for cracks and holes with penetrant. Replace any damaged plates.

INCREASED PRESSURE DROPS PROBLEM

The pressure drop is higher than the design value.

POSSIBLE SOLUTIONS

- ° Check the accuracy of the measuring instruments used.
- ° Test the operation of the pumps.
- ° Fouling may be the cause. Clean the heat exchanger.
- ° Circulate the fluids in the opposite direction to remove any blockages in the pipes.

VARIATIONS IN TEMPERATURE PROBLEM

The heat exchanger's outlet temperatures do not correspond to the expected temperatures.

POSSIBLE SOLUTIONS

- ° Check the accuracy of the measuring instruments used.
- ° Fouling may be restricting the flow along the channels and reducing the heat transfer capacity (drop in efficiency). Clean the heat exchanger.

6 - DISPOSAL

- Disconnect the heat exchanger from its power sources and wait until it has cooled fully.
- Drain the heat exchanger and collect the fluids in accordance with environmental standards.
- Dispose of the gaskets in accordance with the prevailing legislation.
- Use the lifting systems employed when installing the heat exchanger.
- Check whether any part of the heat exchanger may be recycled for another purpose.

Materials:

Consult the documentation provided with the order for information on the materials used to fabricate the heat exchanger.

- Plates: stainless steel or titanium.
- Other metal components: carbon steel or stainless steel.
- Gaskets: NBR, EPDM, FPM, HNBR.

Insulation or plate protection materials: stainless steel + ceramic or aluminium + polyurethane boards or cross-linked polyethylene.